

Florere Hotel

History/Site access

First Century 43-406

The first settlement on the British land was made by Romans who extended the Roman empire from Europe, into the UK, through the construction of Londinium (today's London). Romans adopted the thermal baths as an important way of relaxation.



WELL-BEING

Seventeenth Century 1685-1700

Huguenots were the French protestants refugee class who arrived in England due to the war of religions in France. England was one of the countries where they found peace regarding the practice of their religion. Despite the unfortunate event, they tried to rejoice their life through operas as a way of having fun and socializing.



ENTERTAINMENT

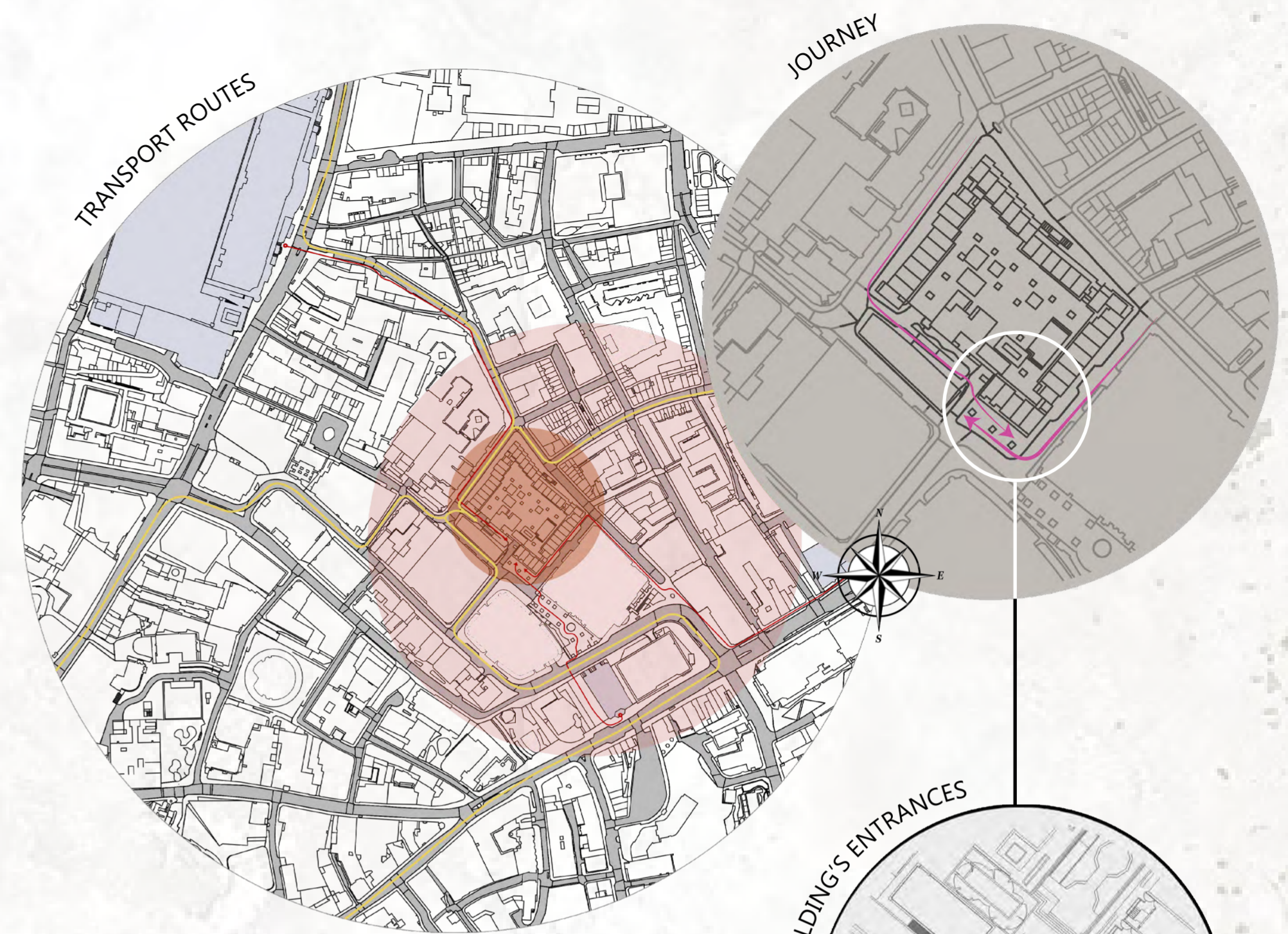

- ALDGATE
- MIDDLESEX STREET ESTATE
- UNDERGROUND STATIONS (LIVERPOOL STREET, ALDGATE, ALDGATE EAST)
- WALK ROUTES
- TAXI ROUTES
- RESIDENTS ENTRANCE
- LA PIAZZETTA RESTAURANT ENTRANCE
- SQUARE MILE DENTAL CENTRE
- ARTIZAN STREET LIBRARY AND COMMUNITY CENTRE
- USUAL PEOPLE'S JOURNEY AROUND THE BUILDING

Nineteenth Century 1882

After the persecution of the Jewish people in Eastern Europe, a wave of Jewish immigrants found their place in London, occupying Whitechapel and Portsoken Ward. The dinner is one of the moments when Jewish pray before and after serving food, alongside their family or community, which makes the action to contribute to the sense of spirituality and intimacy.



COMMUNITY/FAMILY REUNION



Site analysis/Demographic and Business case

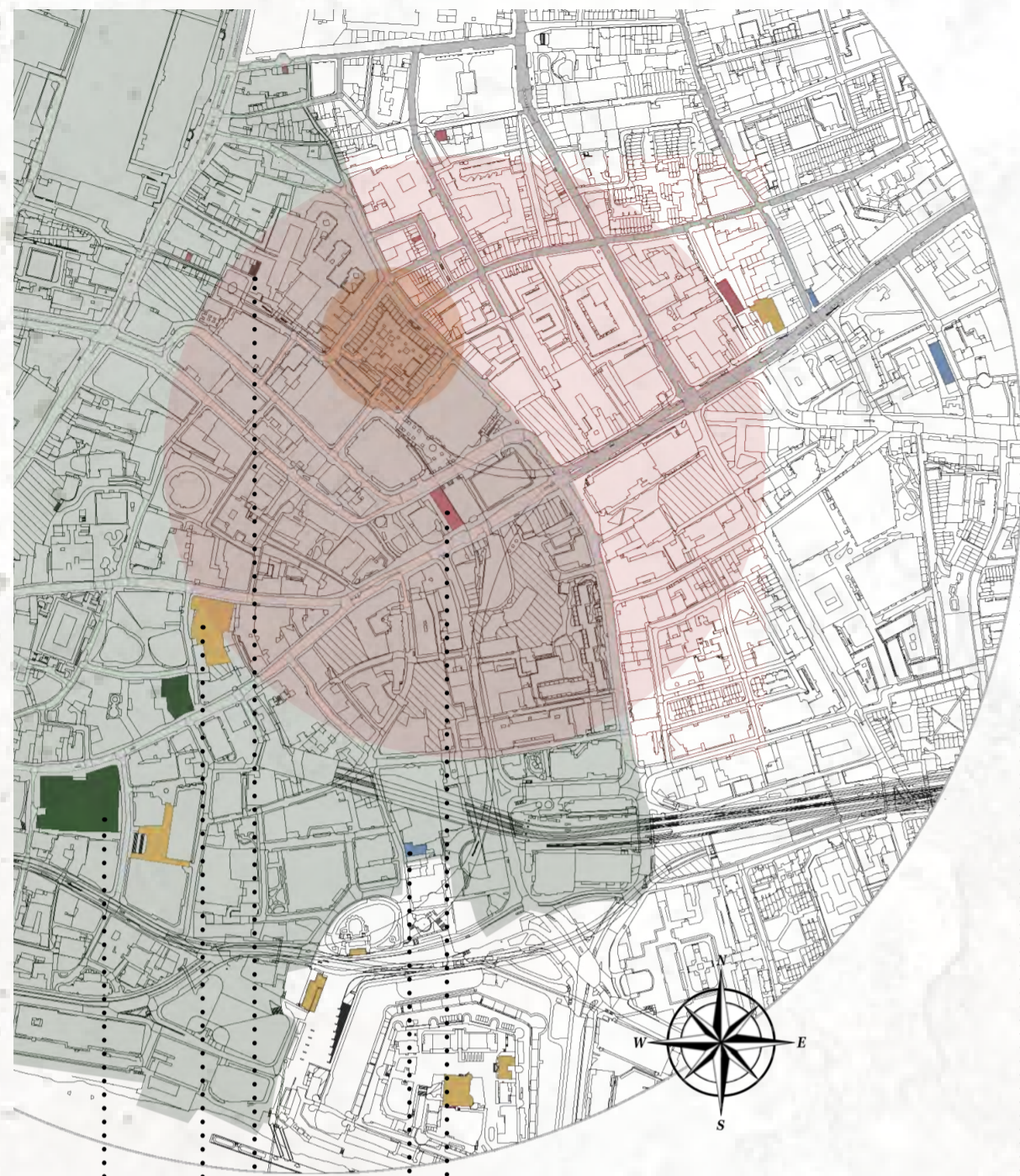

- City of London
- Aldgate area
- Petticoat Square
- Zones under construction
- Spa
- Yoga/Health & Beauty shops
- Tourist Center
- Tourist attractions
- Gardens/Spaces to relax

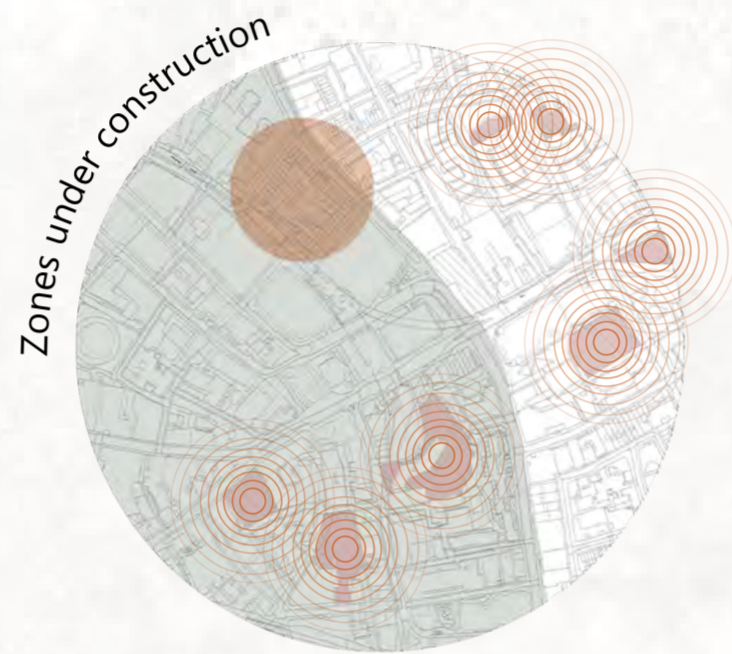

POPULATION

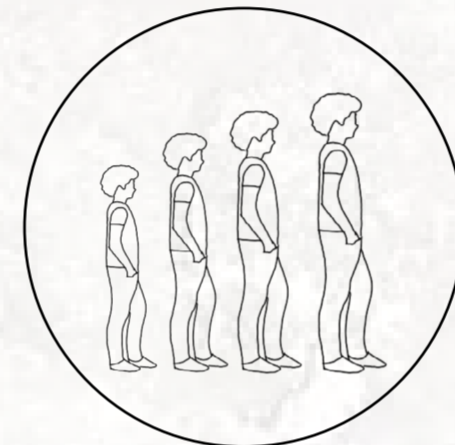

AGE



EMPLOYMENT



EMPLOYMENT FIELDS

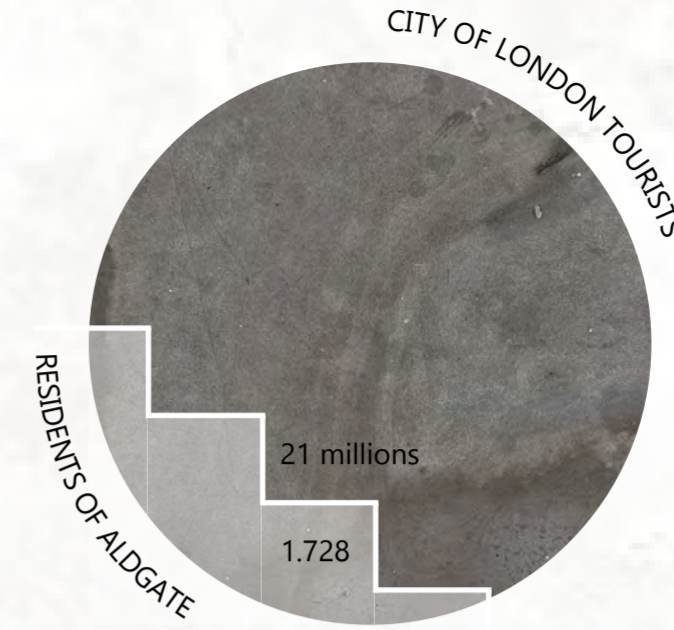

The age between the audience is quite similar and shows that the guests from both sides, community and travellers are young and can be open to different activities, adding a plus to the hotel purpose.

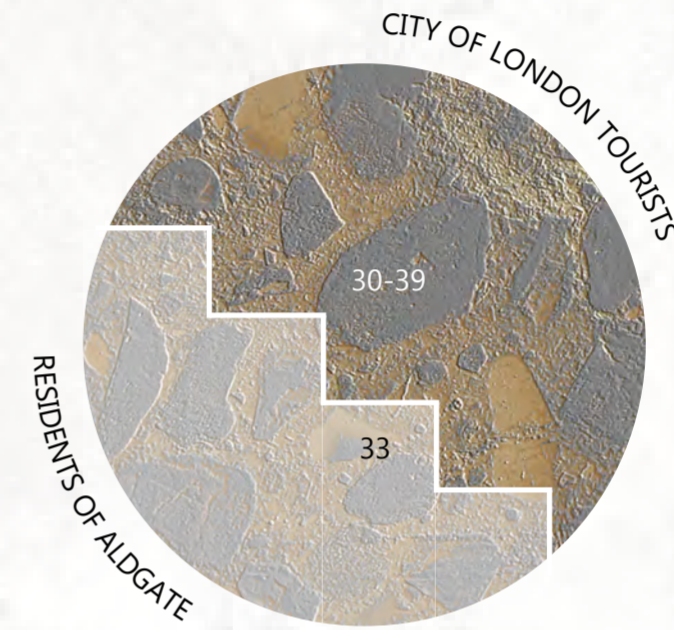

The number of tourists is massive than the number of residents which shows that the hotel has the potential to be fully booked.



The employment may differ from residents and tourists, Aldgate being home for students too, where most of the students from various fields are not commonly found in relaxation hotels during study and travel or during apprenticeship. Most of the residents are employed in property, finance, or retail fields, making part of the business sector, which is quite common for tourists who may come from business sector with work & travel or only for their holiday. Some of unemployed people from community can benefit of new job opportunities created by the hotel, having the opportunity to work around home, alongside students that may need a part-time job, close to their universities, while some travellers who are unemployed may come from different fields with health problems that are putting their work in difficulty.



Aldgate area is represented more through business or corporations, showing that people are travelling to and spending more time in Aldgate for work purposes. Zones under constructions are visible, showing that Aldgate is in a continuous development, most of the construction are made to erect new buildings in order to create more space for business and corporations.

In Aldgate area are visible only two spas, showing that people working in the zone and the residents do not have great diversity to choose from regarding relaxation, and they need to travel more than 5 minutes by walk to reach one of the closest garden, museum, or Yoga studio, or to go to a shop that displays healthy products.

The noise in the area is quite high due to the high volume of traffic and construction machinery used in the zone.

The future hotel will require insulation to cover the noise created in Aldgate area.



Client portrait | Concept

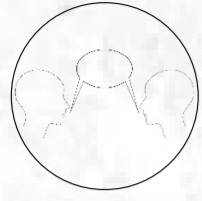

INTERACTIONS

Interactions have a powerful impact on person's behaviour, sometimes being negative or positive and can depend of other individuals and their actions and of course, on the person's cultural background.

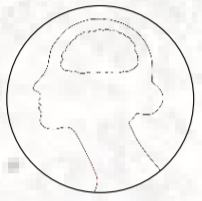

PHYSICAL HEALTH

Physical health is generated through the person's choices and depending on his environment, as well, being influenced by psychological health.



INDUSTRY

In a quite equal amount, a person spend time at work or regaining his energy. The time spend at work depending on the job's field polishes and influences the person's behaviour and sometimes because of work, a person set less emphasis on sleeping time which usually conduct to psychological and physical health disruption.

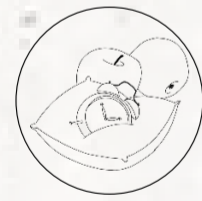

PSYCHOLOGICAL HEALTH

Feelings are generated through different activities and experiences which take place through all aspect of life. The main feelings are happiness or sadness which generate further feelings.



PERSONAL SPACE

Personal space is the person's background with defects and qualities which largely polishes a person's behaviour, conducting to different thoughts and emotions, which lately polishes physical health.

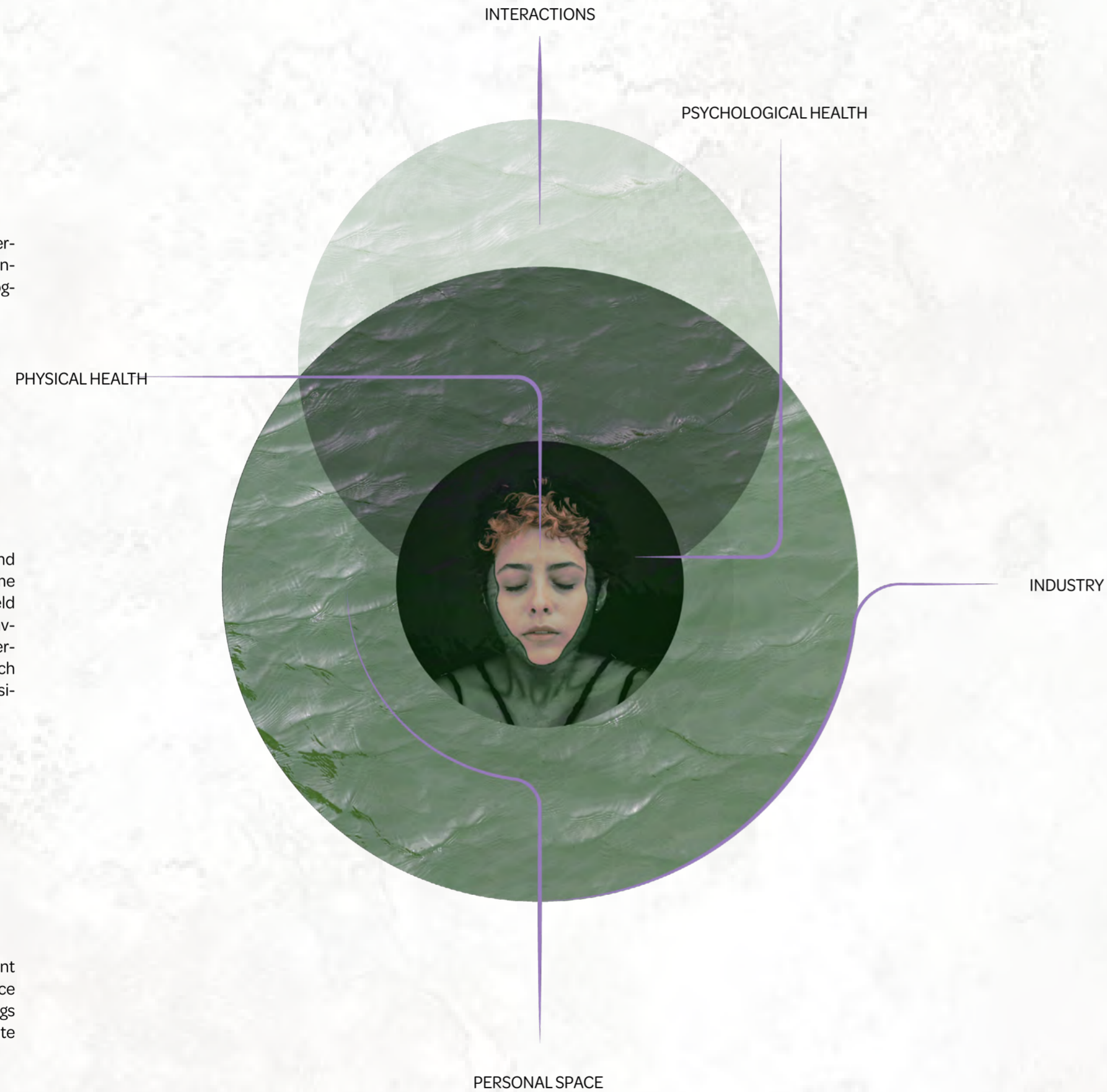

Florere Hotel

Because Latin was the language spoken by Romans and is the mother tongue of most of the European languages, with a descriptive elegance and refinement, the hotel, through its purpose will be known as FLORERE HOTEL. Translated, florere is the representation of today's word 'bloom'.



Romans, the founders of Londinium, today's London, focused on recreational activities such as socializing, reading and highly important, bathing, the majority of the Roman cities then benefited from numerous roman baths. Taking into consideration that in that period people put the accent on recreation, today, people relax less, socialise less and work more which raises the level of stress in the body.

Middlesex Street Estate has the ability through its location to become an attraction point as a recreational hotel in one of the most crowded metropolises of Europe where the neighbourhood or national and international guests can benefit from relaxation spaces such as thermal baths, spacious massage rooms, tearoom, reading zones or rooftop garden. In addition to the stress relief activities, the design will be compounded through pleasant warm colours, organic shapes and geometric shapes that offer comfort and confidence.

Because the concept incorporates well-being through stress relief activities for its guests, sustainability will be adapted to the construction by using different materials that are recyclable or abundant and renewable energy in a friendly and elegant manner that respects the ideology of high-end hotels.

"Form ever follows function"

Louis Henri Sullivan - Architect

Sketch model | detailed drawing

@ scale 1:20

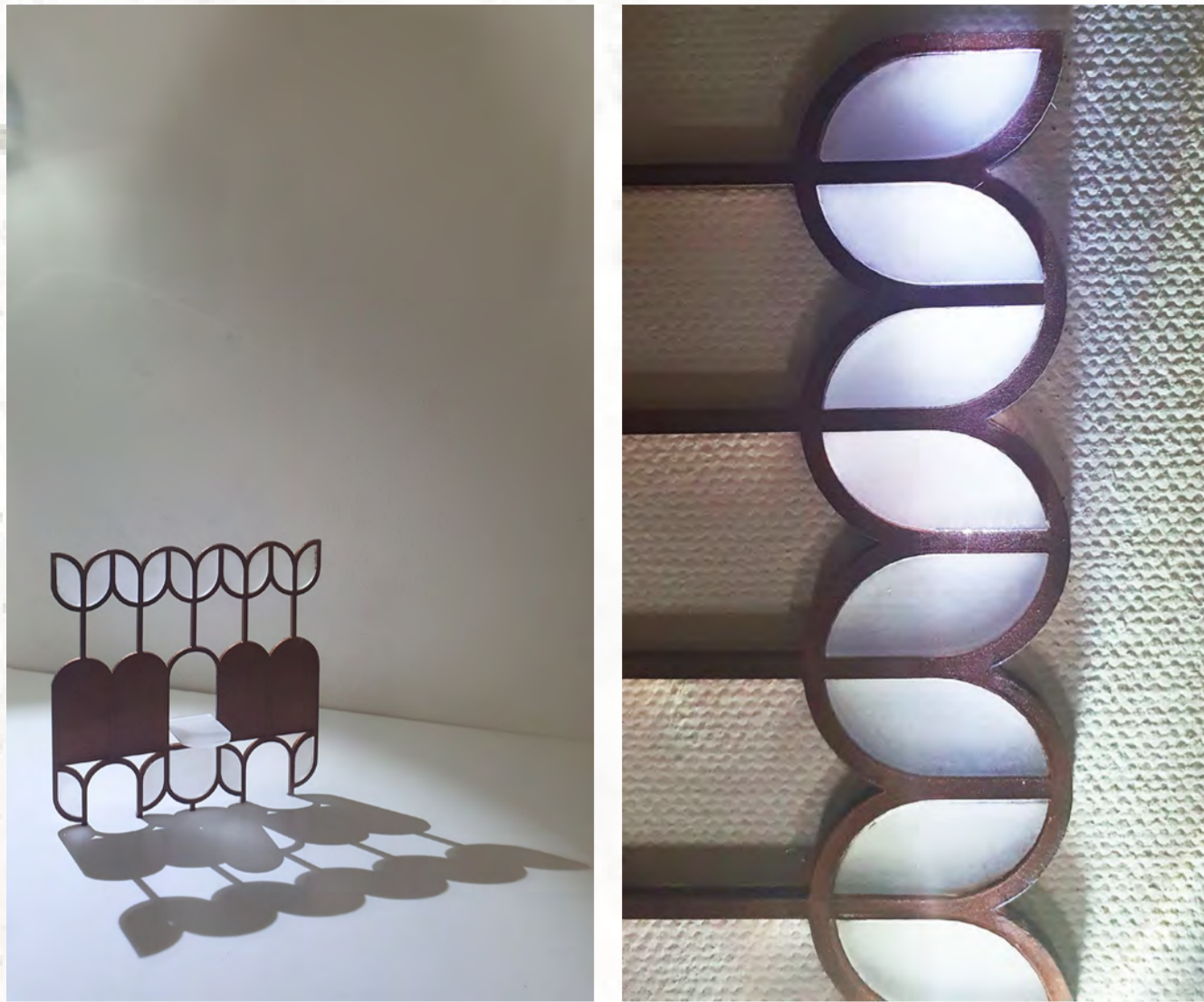

The proposed artefact which is the main decoration element has the flexibility to become a table when needed. The gaps found at the bottom of the article serve as an insertion lot for the stools



@ scale 1:25

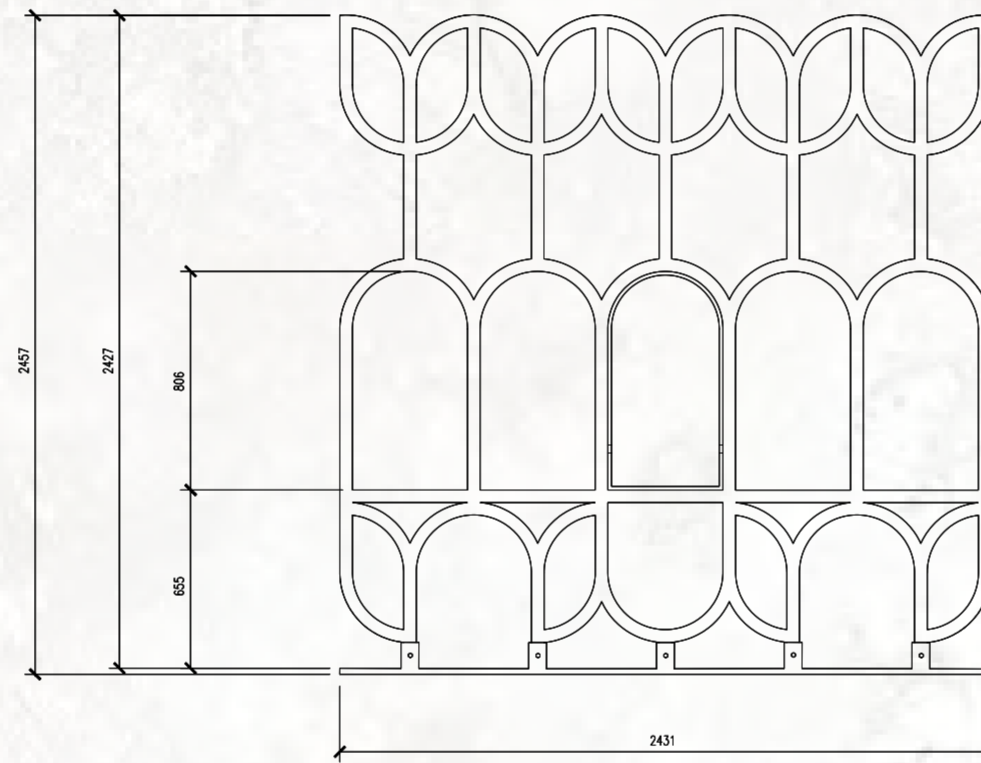
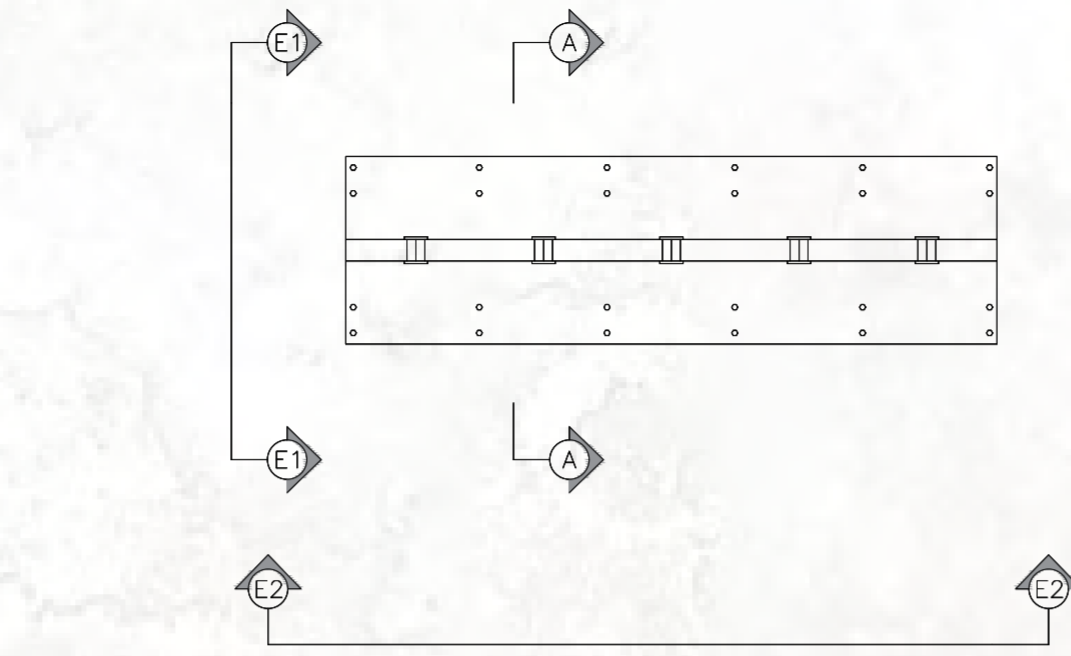

ELEVATION 2

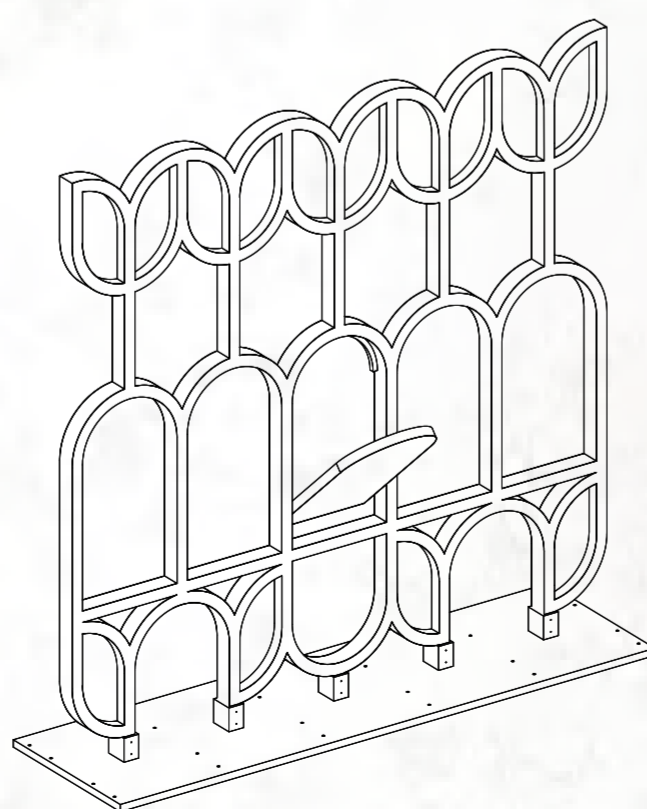

@ scale 1:5

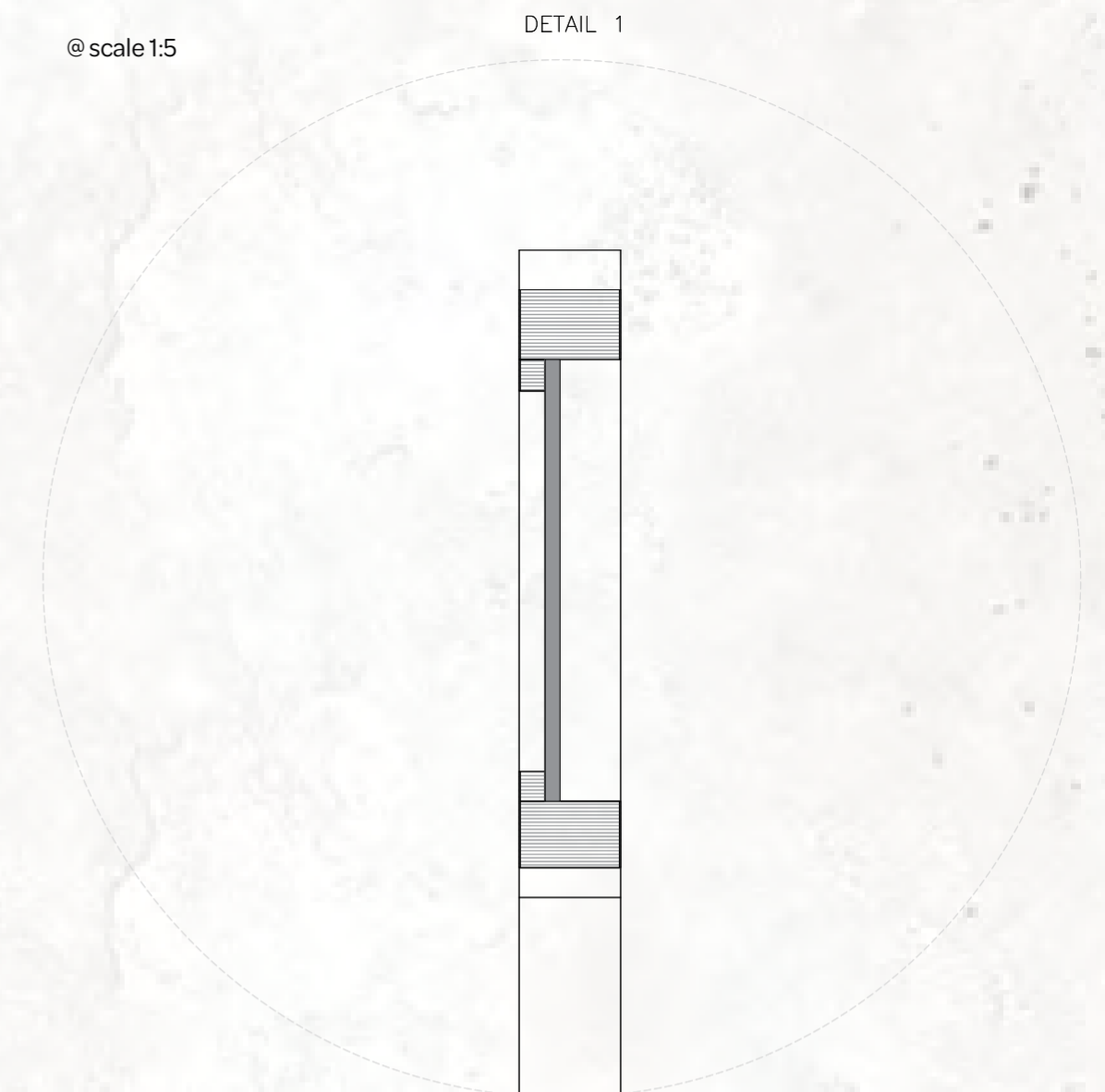

DETAIL 1

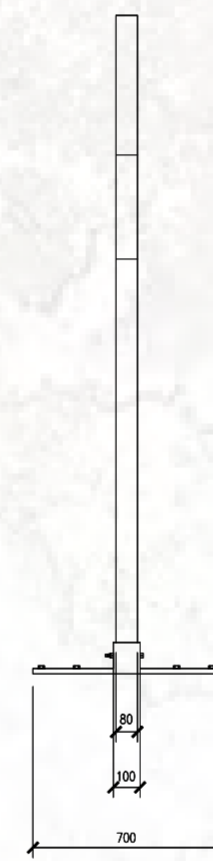

ELEVATION 1

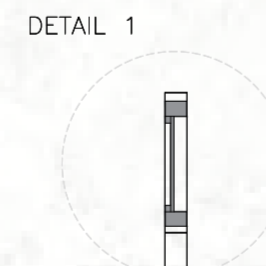

DETAIL 1

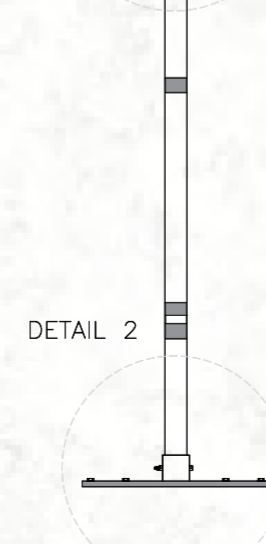

DETAIL 2

SECTION A

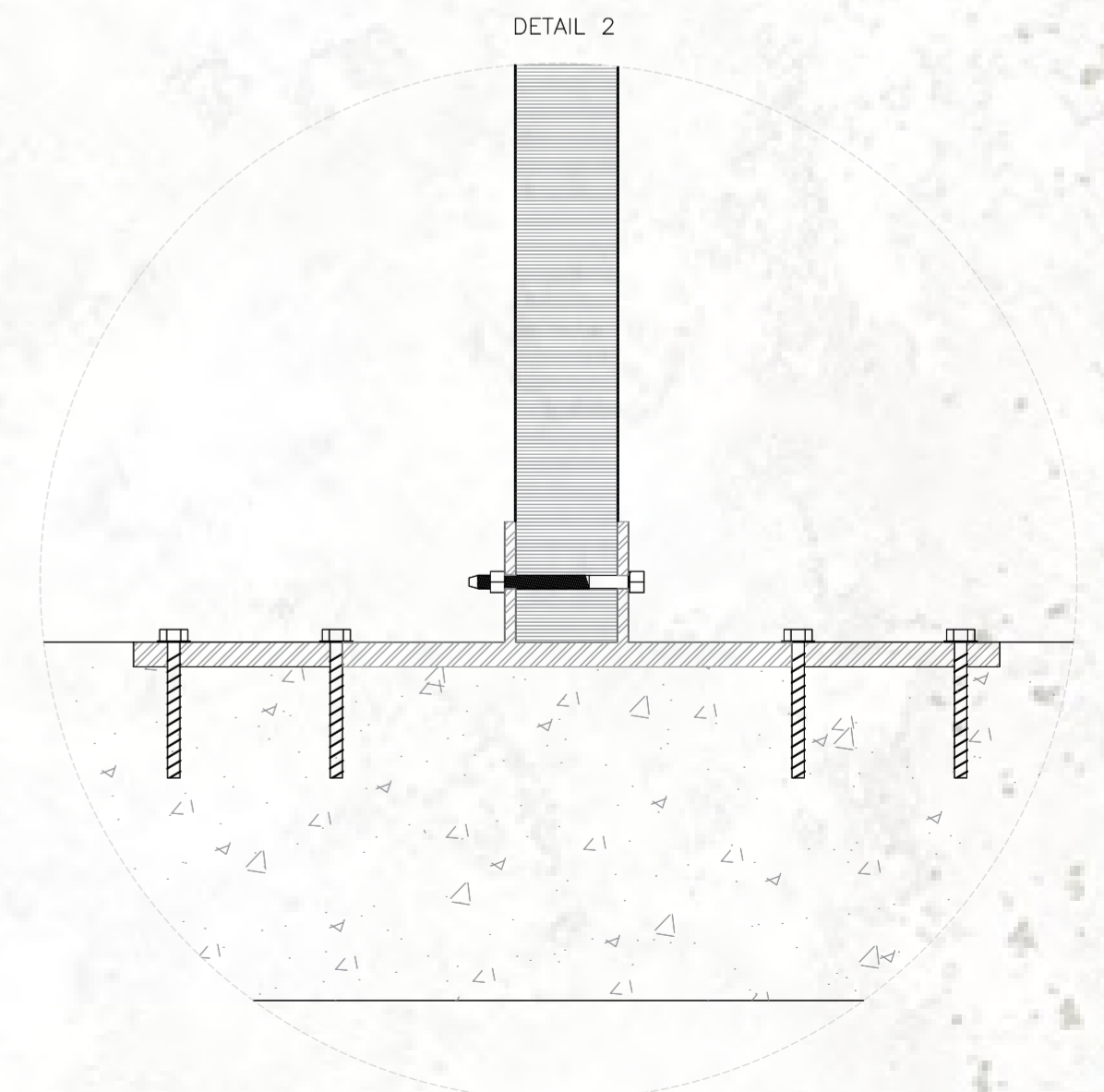

DETAIL 2

Visuals | reception | gathering zone | restaurant | hotel room

