



GREEN COLLECTIVE

Community Centres are important for socialising and forming connections, yet many are in outdated church halls or council buildings and are being forced to close due to a lack of funding. The Green Collective is a project that reinvents the typical community centre by providing a number of sustainable and community focused amenities in a repurposed car park situated in Chester city centre. The proposal provides safe spaces for local communities to hold classes, educate and reskill, celebrate the arts, keep fit and healthy, support new business and celebrate a diverse range of people. The scheme incorporates a range of sustainable features such as rooftop gardens, upgraded external finishes and interior elements in addition to sustainable systems such as micro-power generating gym equipment, rainwater harvesting and solar panels. Design features provide inclusive and circular elements that encourage the re-use, re-telling and re-working of stories, materials, skills and energy.

PROJECT LOCATION: CHESTER



EXISTING SECTION

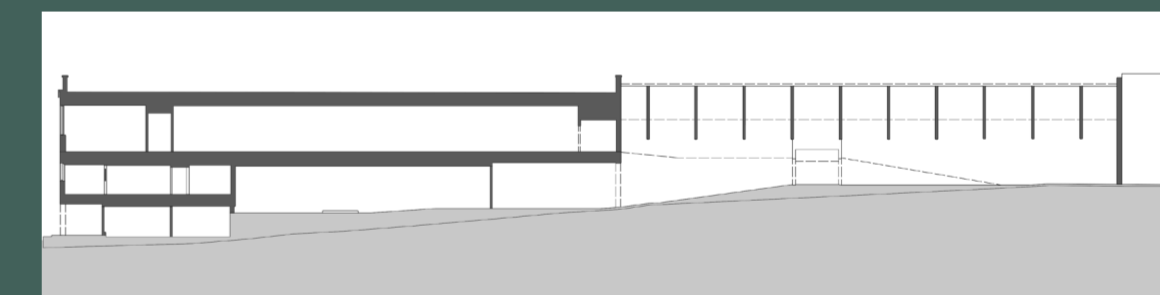

SUN PATH ANALYSIS

Optimising the natural light in the building is important for mental health, as well as sustainability. Adding an atrium to the centre of the building and allowing for double height space around the major area of the sun path, will allow for more sunlight to travel through the building and help with heating and air flow during the different seasons.

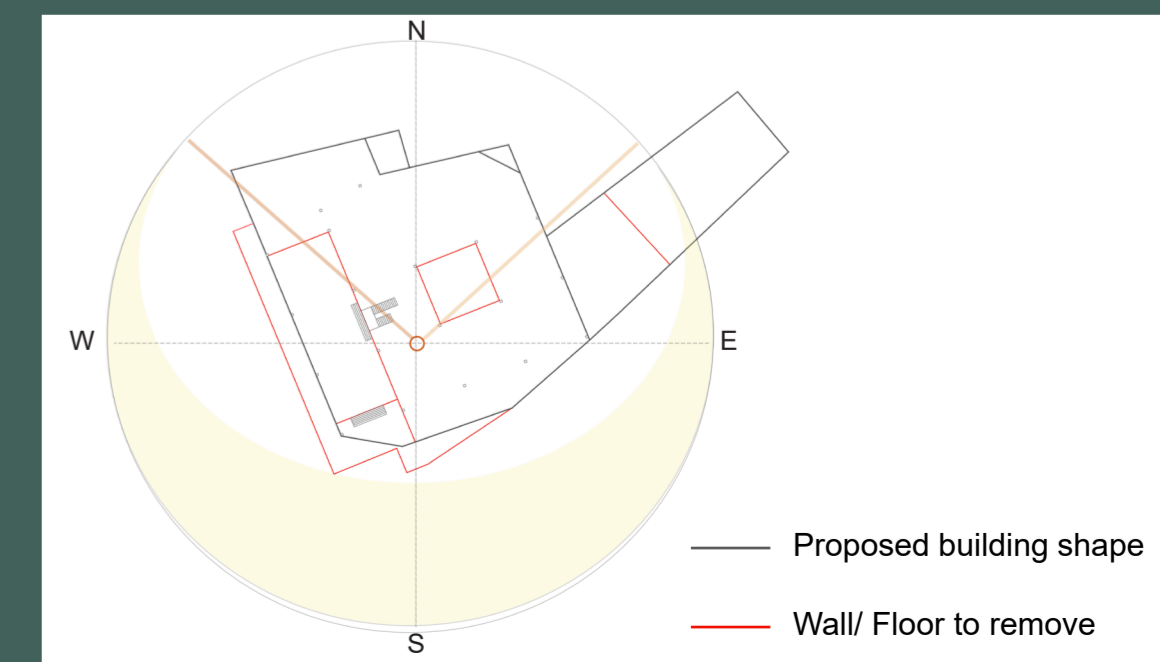

USER RESEARCH

To gain better information for what the community needs a questionnaire was shared between people online. The questionnaire results showed the biggest response were 30% of people aged 18-24 and most were women. Of the people that answered 70% stated they did not use community centre services or have one available. However 80% said they believe that community centres are important and that they could have better use for the community than they do now. In answer to question 9. What would you like a community centre to provide?, the main user needs are adaptable spaces, skills/ education, Community support and social areas i.e cafe. The centre would need to be flexible and inviting to many different ages and groups within the community as well as incorporating sustainable core principles of design to complete a holistic aproach. Many members of the area are already part of groups within the community for example: sports groups, book clubs, drama groups, baby/parent groups.

QUESTIONNAIRE:

1. What is your age?
2. What is your gender?
3. What area do you live in?
4. Do you use or go to a community center for any services, resources or clubs?
5. What services have you or do you use at a community center?
6. Do you think community centers are important?
7. Are you part of any clubs, activities or social groups in your area, if so what?
8. Do you think community centers could be better use for the community than how they are now?
9. What would you like a community center to provide?
10. What else do you think community centers should offer?
11. Do think the design should have an environmentally friendly approach?
12. Do you know what sustainability means?
13. Do you think it is important to educate people on sustainability and global warming?

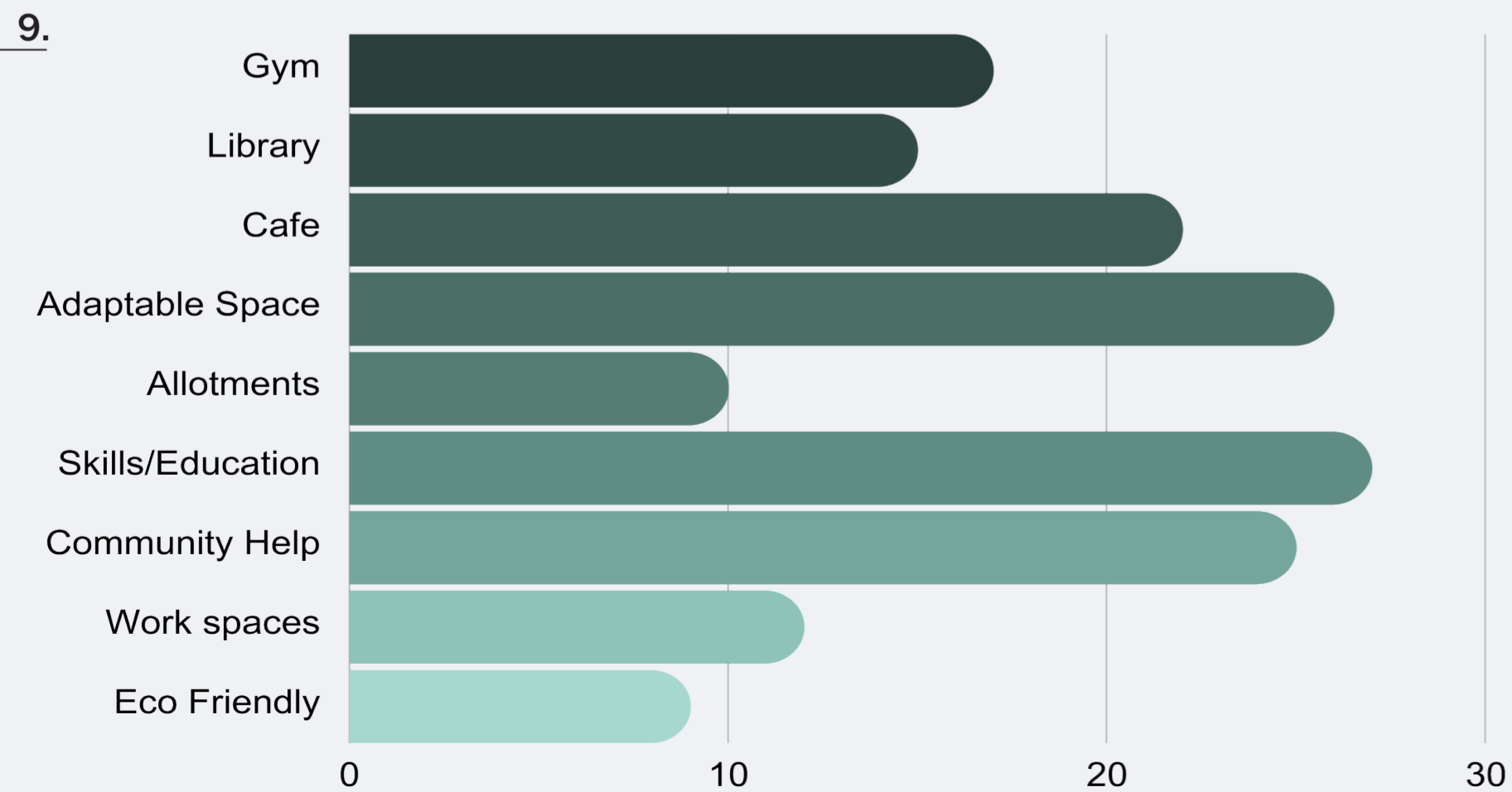
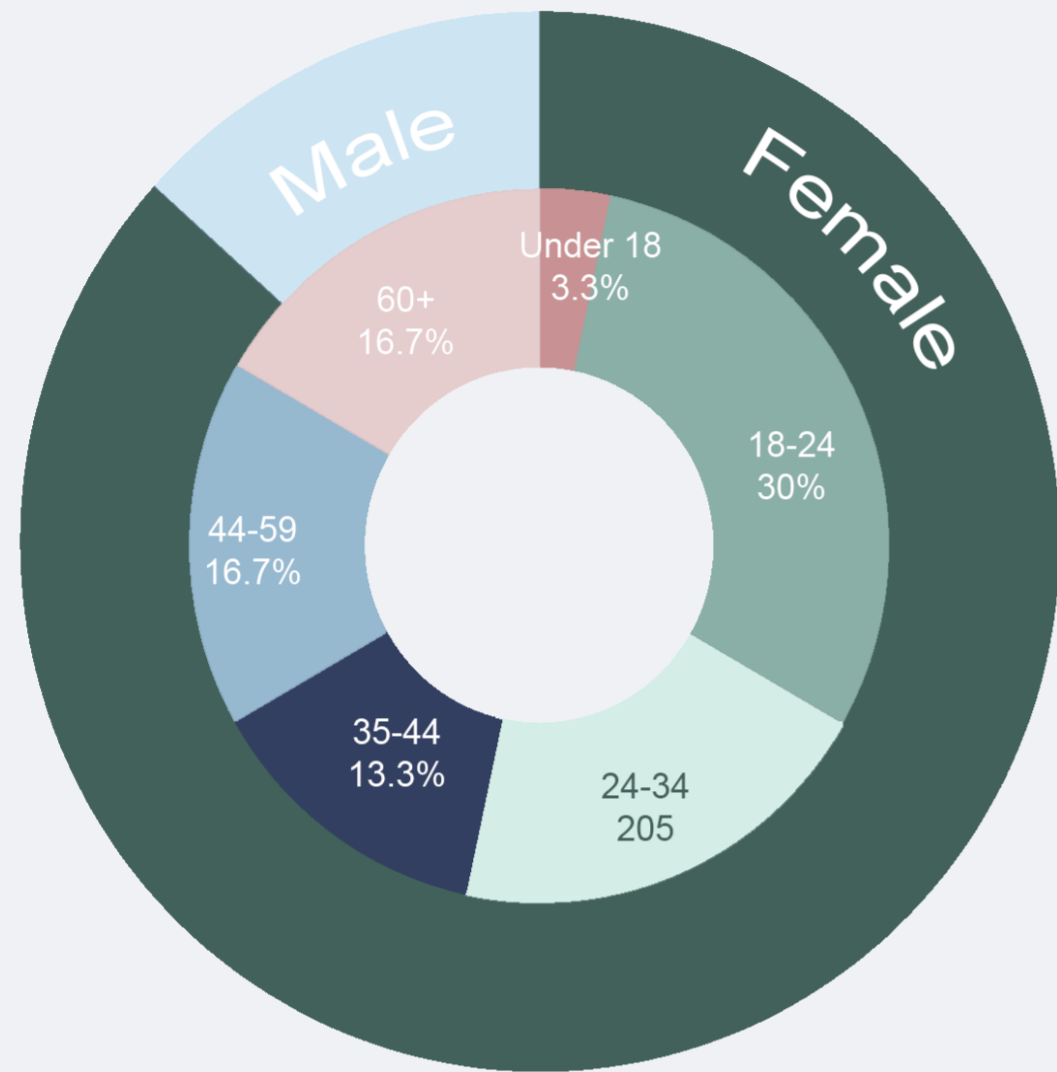

PROJECT OBJECTIVES

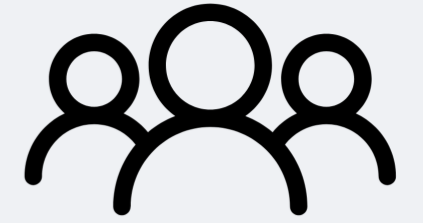

1. COMMUNITY

To create a space that brings the community together and provide a sense of belonging. Allowing people to connect and find support while also offering a chance to give back to the area of Chester and help the less fortunate.



2. SUSTAINABILITY

To use sustainable systems to create a building that is more self sufficient as well as saving long term costs and lowering the buildings CO2 emissions. Using sustainable materials and circular design to reduce waste and create a eco friendly environment.



3. EDUCATE

Creating opportunities for education, re-skilling and learning for all ages. A design that can educate on circular systems and sustainability. Also offering generations opportunity to re-skill, pass on life experience and re-connect with older or younger generations.



4. INNOVATIVE DESIGN

Forward thinking design decisions that will create an inspiring environment. Designing for the user wants and needs in a sustainable way, looking at past design and improving, creating things that are new and thoughtful.

HOLISTIC DESIGN

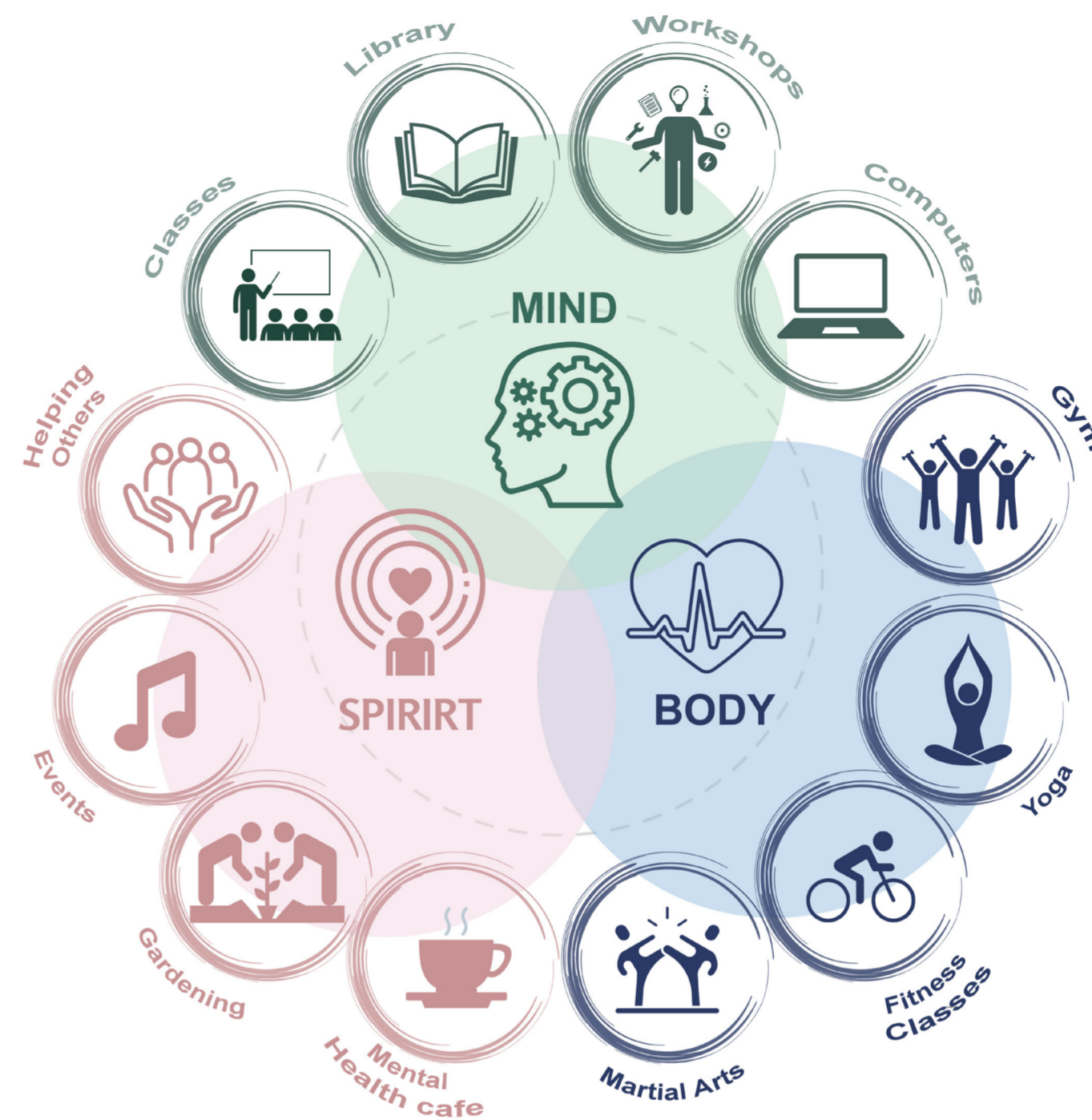

USER GROUPS

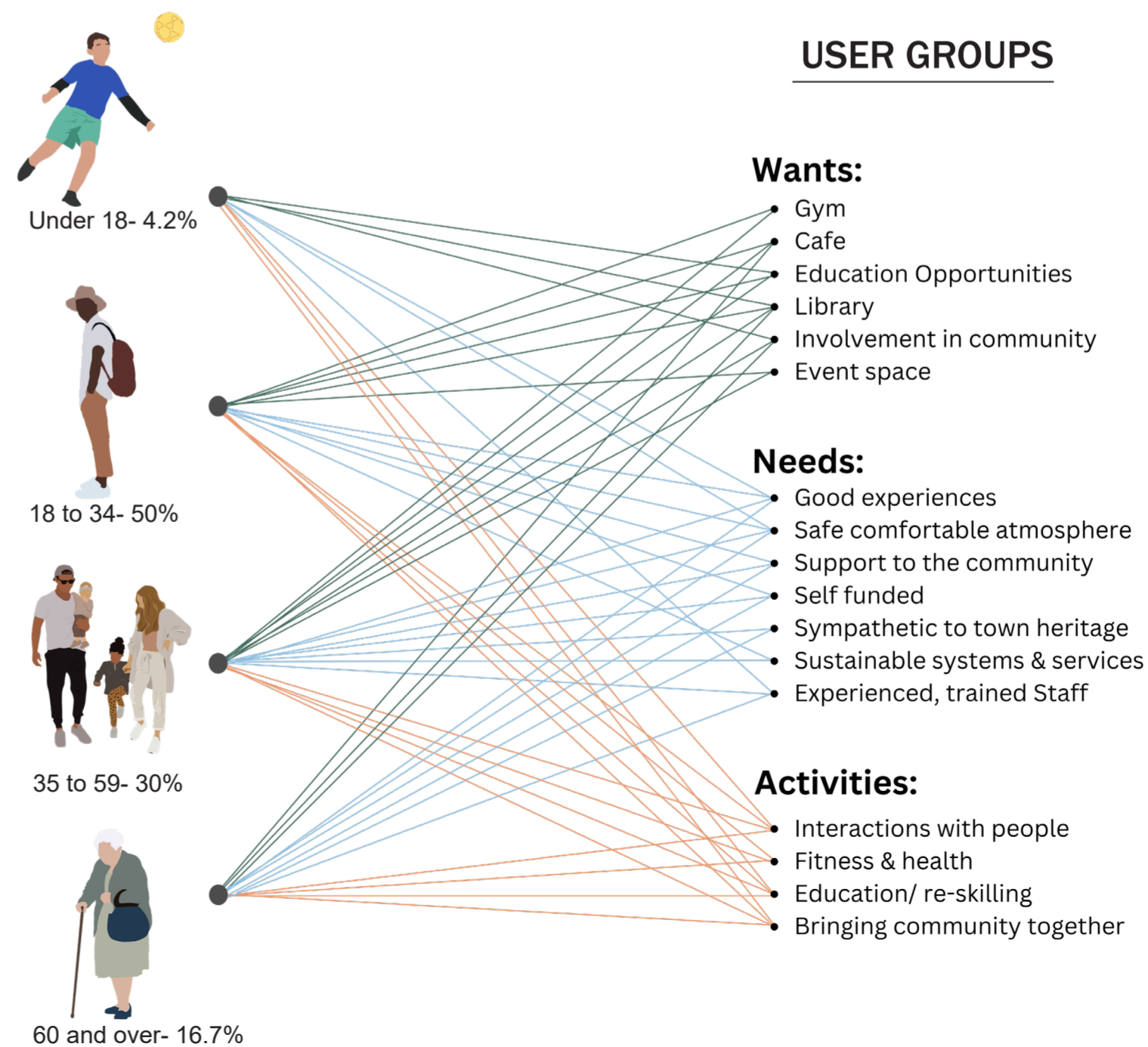

RESEARCH APPLICATION TO DESIGN

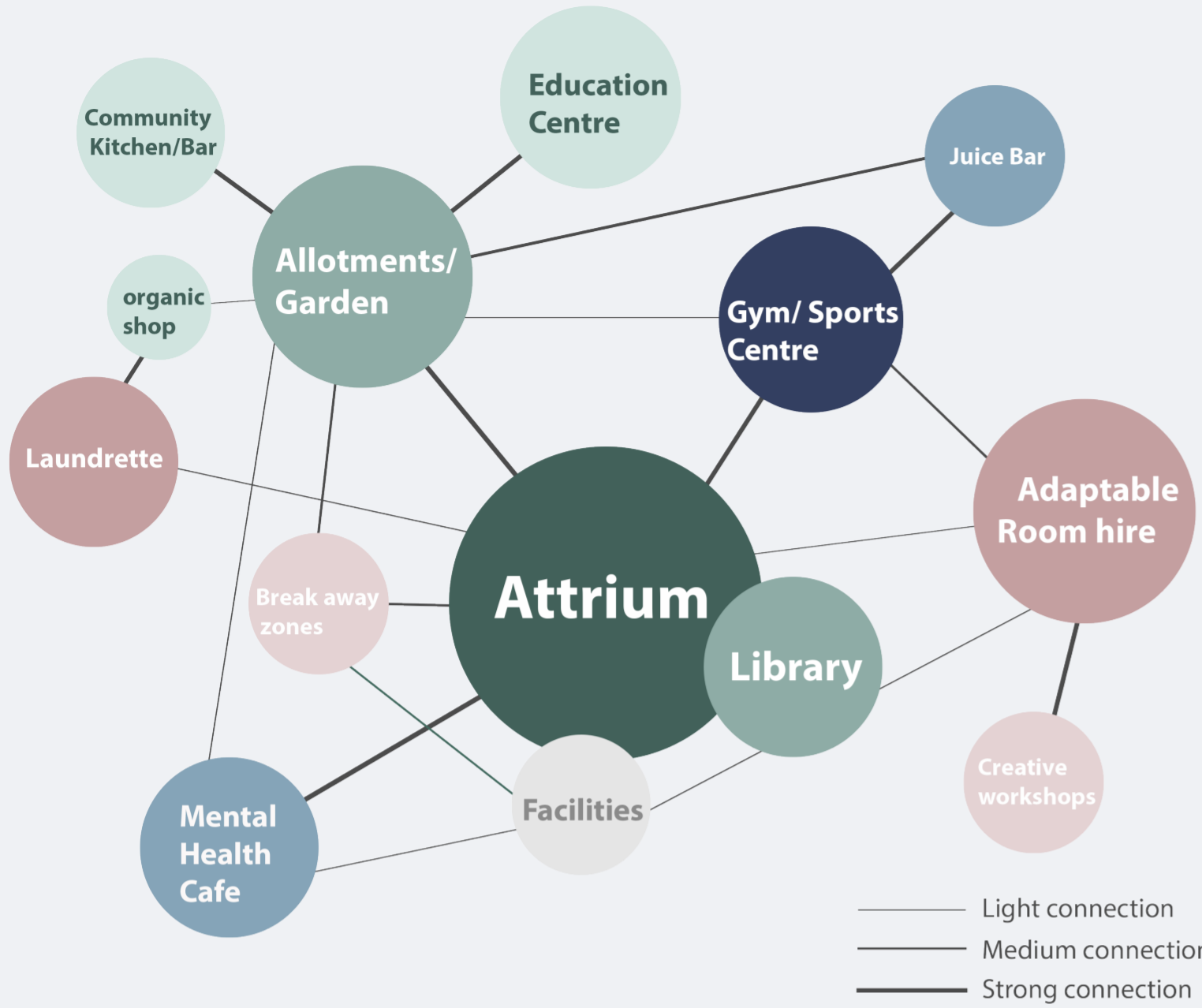

EXISTING GROUND FLOOR



PROPOSED GROUND FLOOR ARRANGEMENT

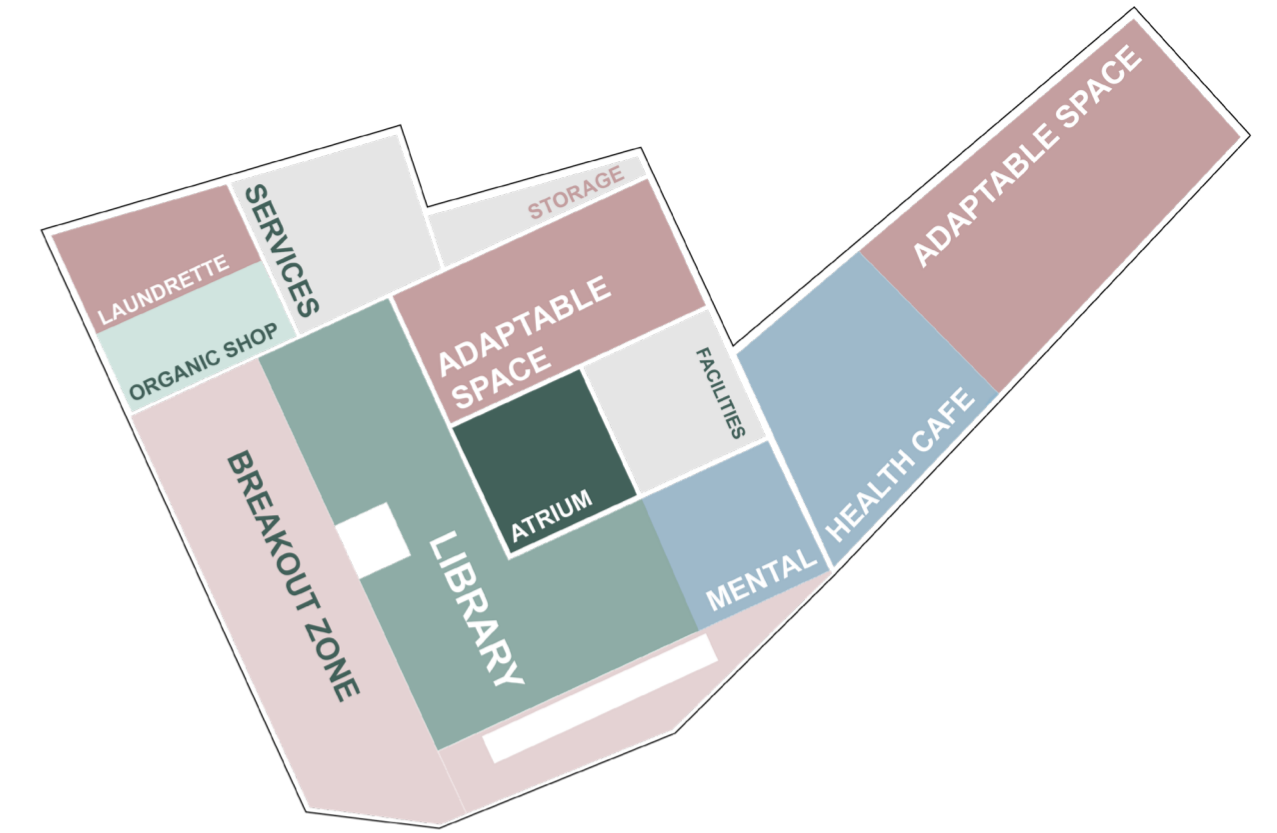

EXISTING FIRST FLOOR

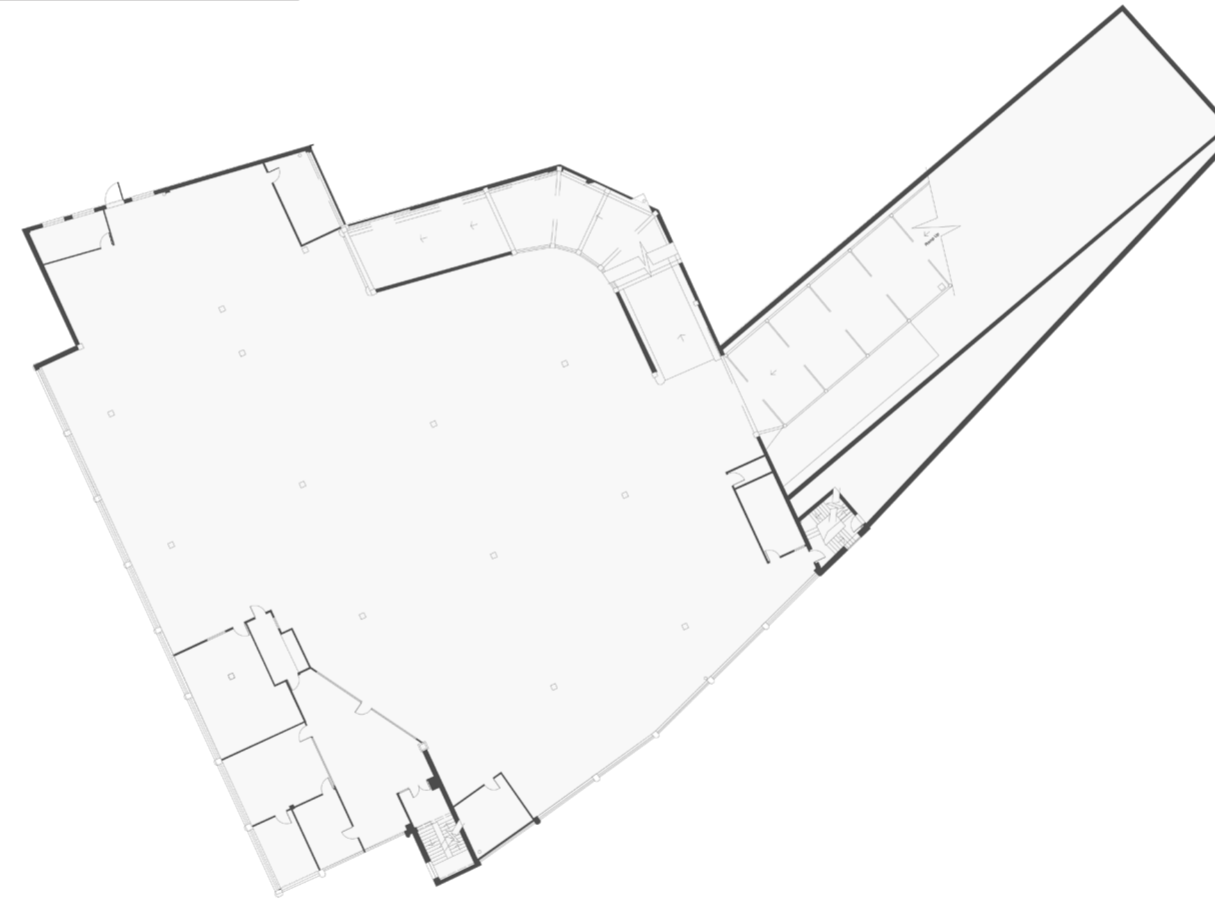

PROPOSED FIRST FLOOR ARRANGEMENT

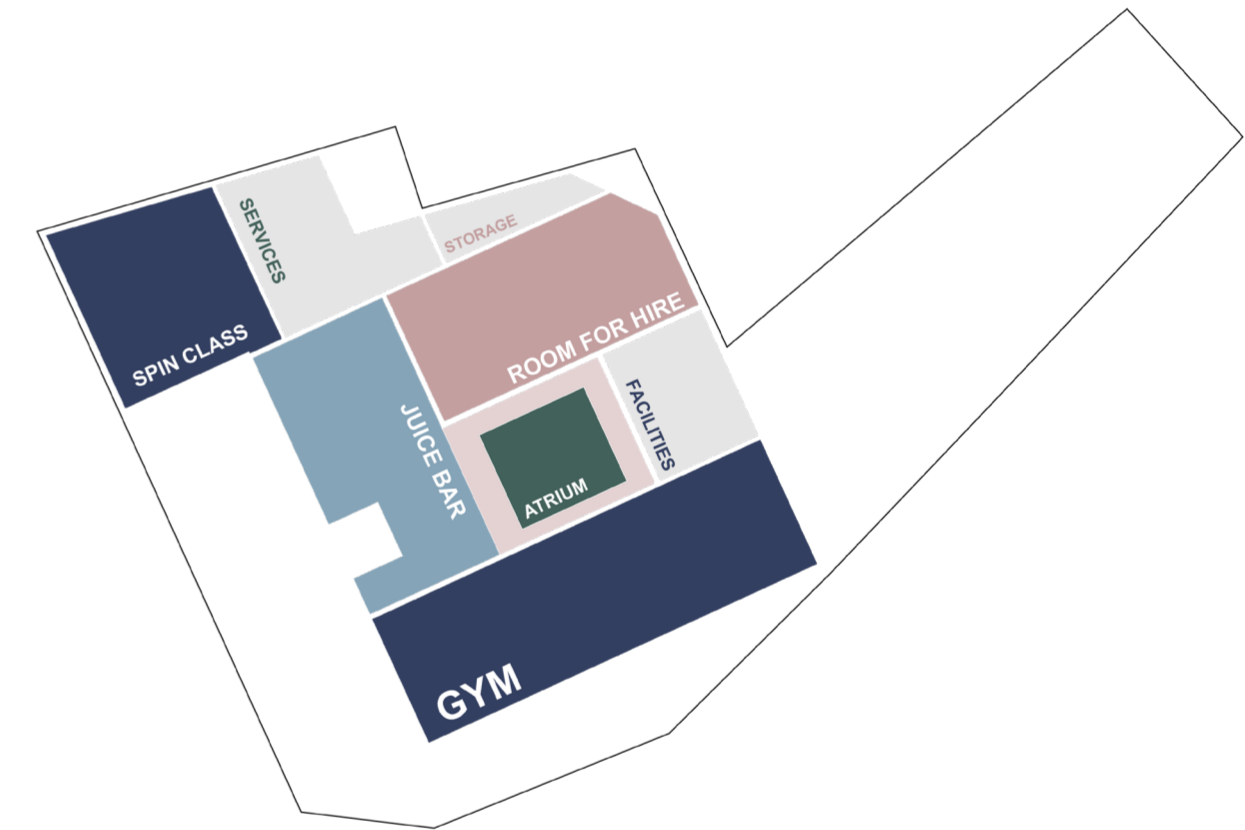

EXISTING ROOF LEVEL

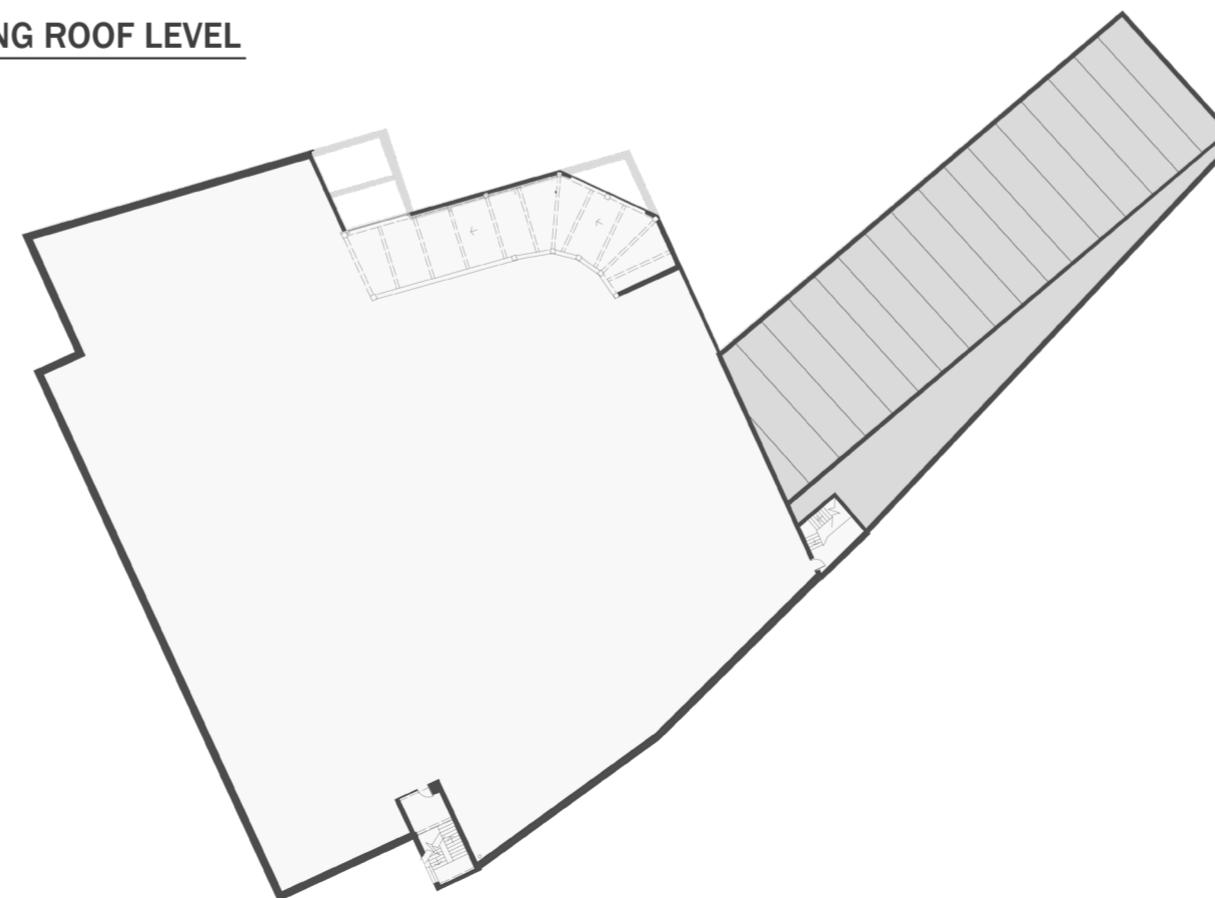

PROPOSED ROOF ARRANGEMENT

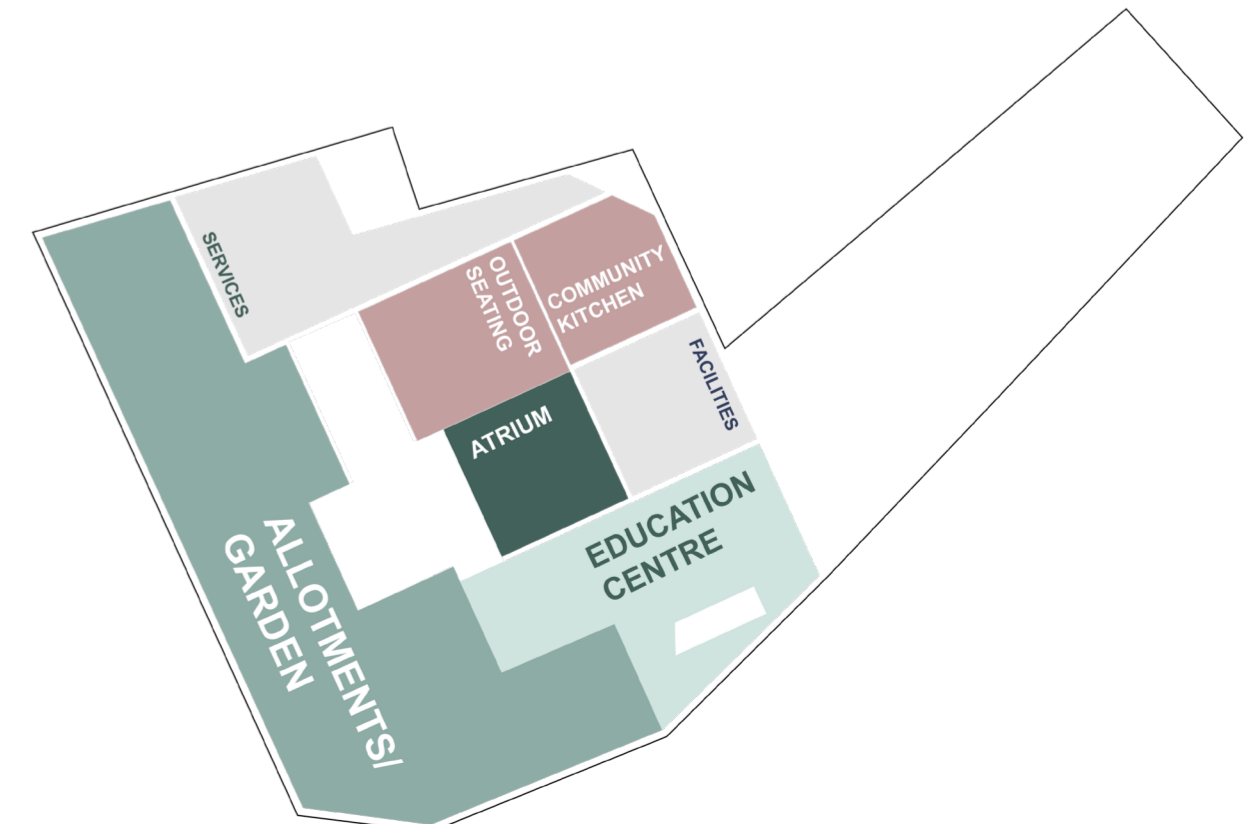

This diagram communicates the relationships between each activity space. The activities proposed are to aid the communities need for connection, education, sustainability and health. The Atrium at the heart of the building, has a visual or physical connection to most areas guiding the flow of traffic through and enticing users to feel calm and explore. Each colour in the spatial connections diagram, is part of the proposed colour scheme, chosen for holistic reasons. The greens relate to the plants and nature, blue is the colour of the mind and is essentially soothing. Strong blues will stimulate clear thought and lighter, soft blues will calm the mind and aid concentration. The pale and more saturated shades of pink are thought to be a calming color associated with love, kindness, and warmth. Each area of the design has been assigned a colour that connects to its meaning.

- Greens representing sustainability, education
- Blue represents health & wellness
- Pink represents community spaces that can have more than one function depending on the user.
- Grey represents general facilities and storage.



GYM



ORGANIC SHOP



LIBRARY

USER ACTIVITIES



CAFE



EDUCATION



SKILLS

DESIGN RESOLUTION



SECTION AA

- 1. Urban Garden
- 2. Window through to spin class
- 3. Gym
- 4. Stairs
- 5. Community Space, access to lifts and sustainable services.
- 6. Atrium and window through to adaptable hall space
- 7. Mental health cafe

- 8. Education Centre
- 9. Outdoor seating area
- 10. Communal space
- 11. Garden area and allotments
- 12. Window through to organic shop/ Laundrette

SECTION BB

- 1. Market hall, extra seating
- 2. Adaptable Space

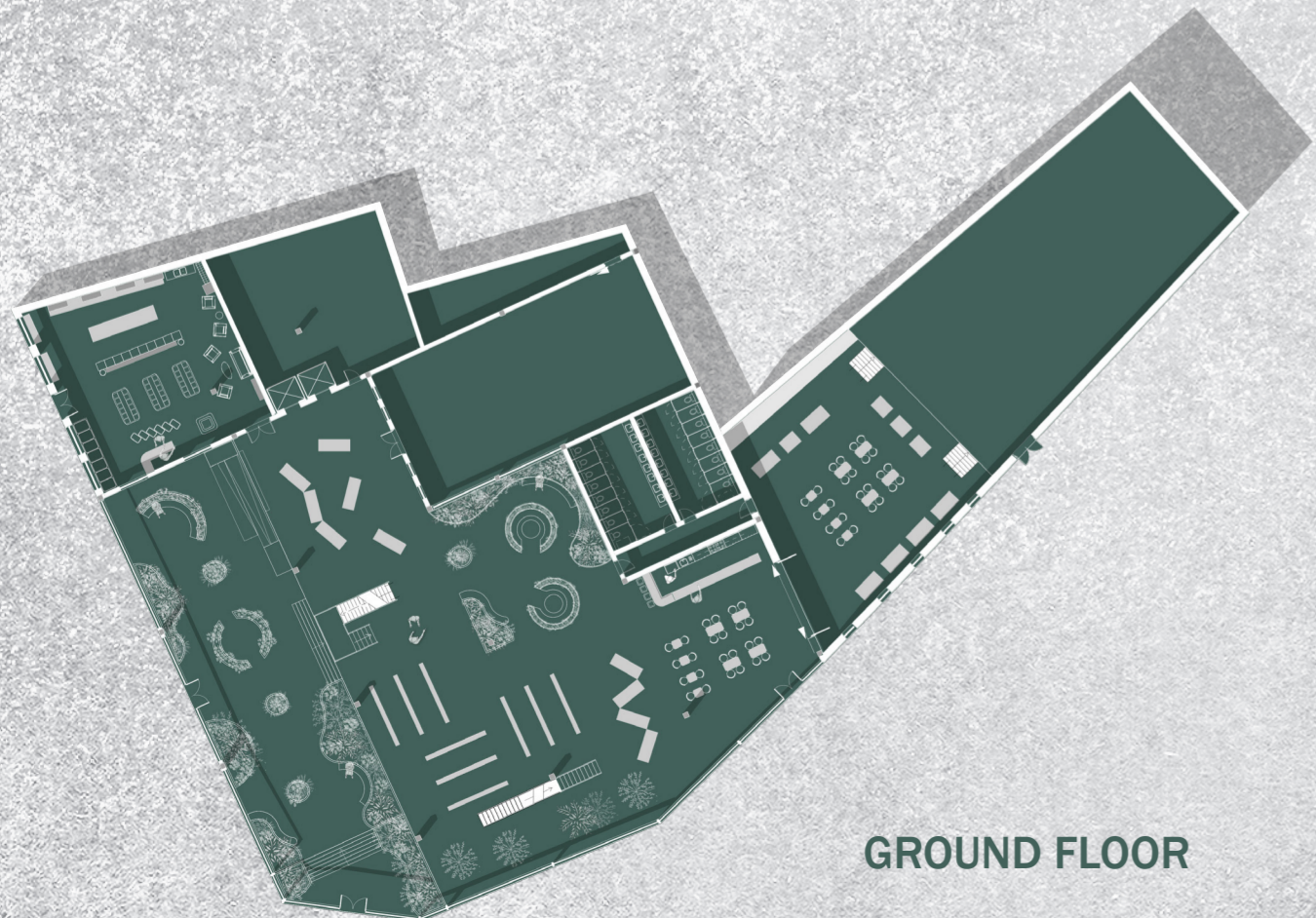
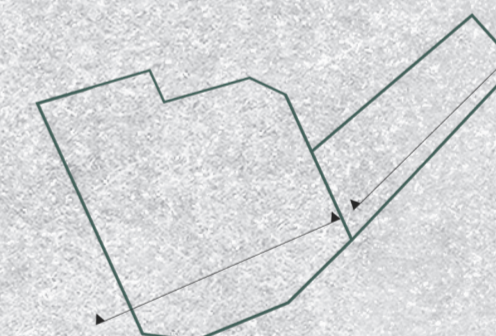

GROUND FLOOR

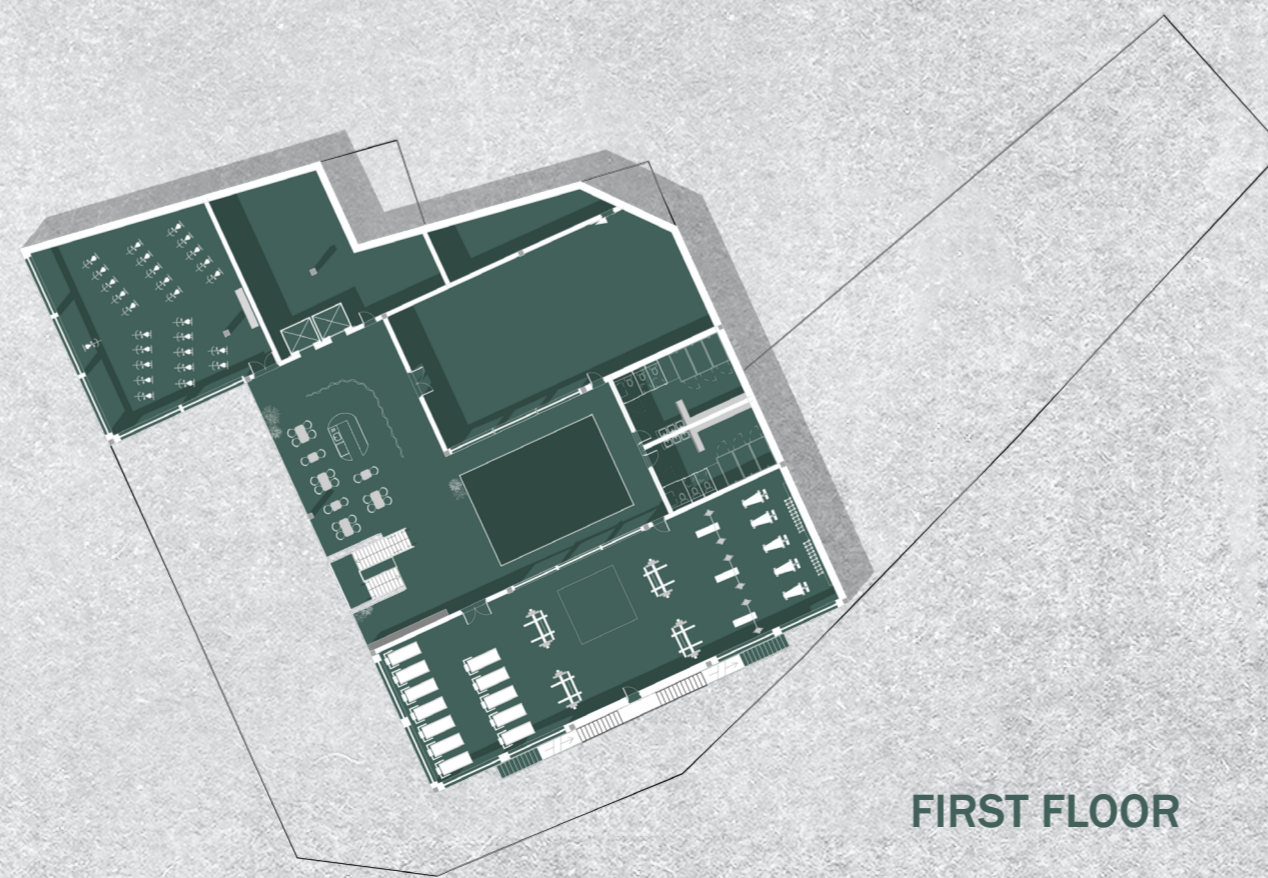

FIRST FLOOR

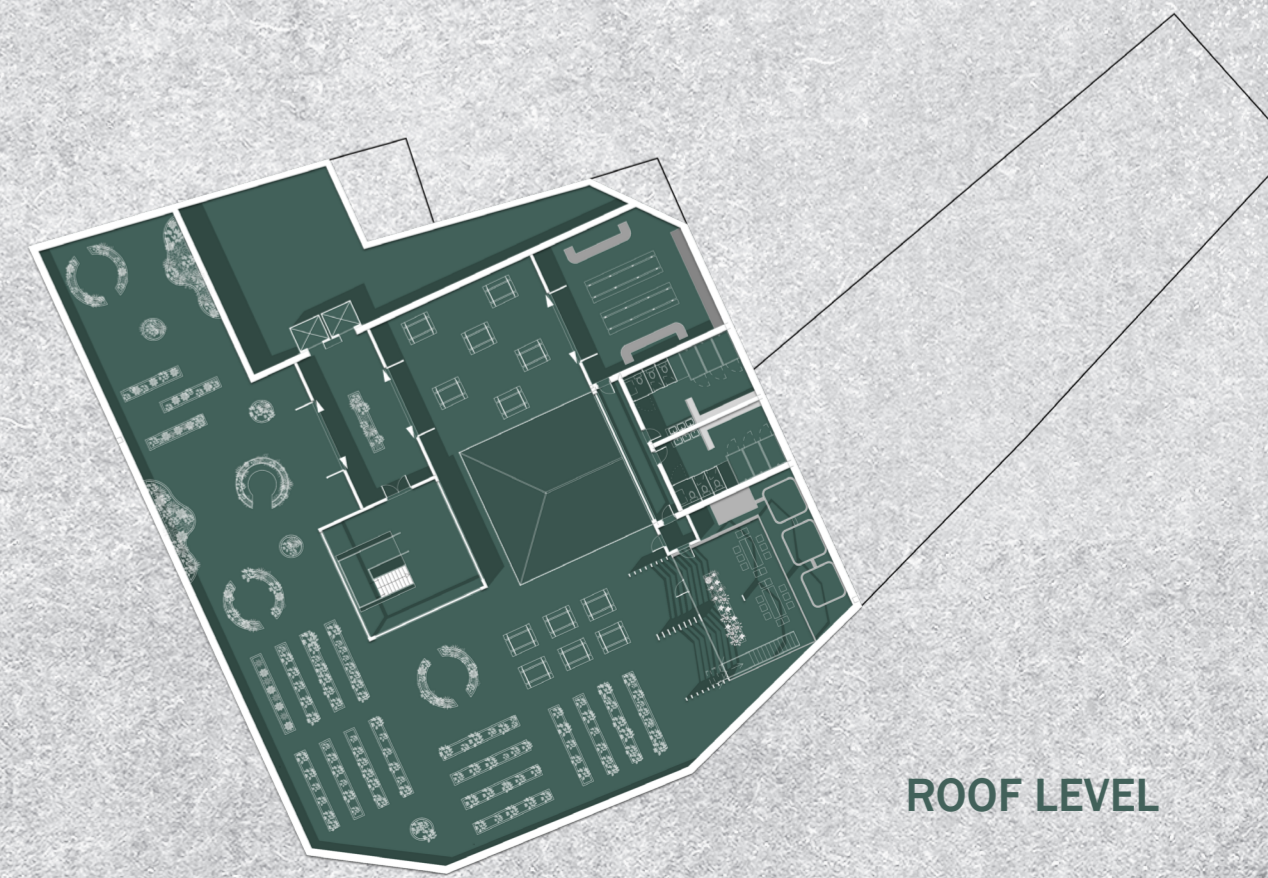

ROOF LEVEL

BUILDING FABRIC MATERIAL BOARD

1. Glass

<https://www.pilkington.com/en-gb/uk/architects/types-of-glass/solar-control-glass#>

Finish: Dual-coated glass with self-cleaning, solar control, and thermal insulation performance.
Manufacturer: Pilkington

2. Clay Plaster wall finish

<https://clay-works.com/classic-finishes/tonal-finish/>

Finish: natural and non-toxic, with low VOCs emissions, Long lasting, with a 60 year lifespan, reusable and biodegradable.
Manufacturer: Clayworks

3. FSC Certified Hardwood Oak Timber

<https://www.timberfocus.com/c24-construction-timber-joist-and-supports/>

Finish: Treated and sealed with varnish
Manufacturer: Supplier Timber Focus

4. Wall Panels

<https://durranel.com/the-product/>

Finish: more durable than plaster board, acoustic properties, fire resistant, reduces CO2 emissions.
Manufacturer: Durranel

5. Pavagen Floor Tiles

<https://www.pavegen.com/about>
Finish: Recycled rubber, absorb and harvest kinetic energy.
Manufacturer: Pavagen

6. Steel

<https://libertysteelgroup.com/uk/greensteel/>
Finish: Treated
Manufacturer: Liberty Steel Group

7. Acoustic Panels

<https://www.baux.com/acoustic-products/wood-wool/panels/lines/>

Finish: Wood Wool
Manufacturer: BAUX

8. Mycelium Insulation Panel

<https://mycellium.co/product/mycelium-insulation-panel/>

Finish: 100% natural mycelium, fireproof and anti-moisture, completely made with mycelium material.
Manufacturer: Mycelium



The materials used in the main fabric of the building are specifically chosen for biodegradable, or sustainable qualities. These materials are either made from recycled products, sourced from sustainable manufacturers or are made up of biodegradable compounds resulting in zero waste after use.

DETAIL MATERIAL BOARD

1. Acoustic panelling

https://www.baux.com/acoustic-products/wood-wool/panels/?_gl=1*dwccuo*_
Finish: Moisture regulating, sound proof, fire resistant, low emission.
Manufacturer: BAUX

2. FSC Certified Hardwood Oak Timber

<https://www.timberfocus.com/c24-construction-timber-joist-and-supports/>

Finish: Treated and sealed with varnish
Manufacturer: Supplier Timber Focus

3. Plywood

https://www.savoytimber.com/deals/sheet-materials/external-plywood.html?gclid=Cj0KCQjwslejBhDOARisANYqKD2JsmYgCqVHwYwPvR0Wn3CEtBgjPkic3q78b969J2eTcv-J1ycnsaAj_EALw_

wcB

Finish: Treated and sealed with varnish.
Manufacturer: Savoy Timber

4. Sahco upholstery

<https://www.kvadrat.dk/en/products/upholstery/600167-proof>

Finish: 100% polyacrylic with HITEX-Faser
Manufacturer: Kvadrat

5. Steel

Finish: Galvanised
Used for the D frame rods and the truss brackets.

6. Industrial Castor wheels

<https://gblcastors.co.uk/collections/50mm-castors/products/wheels-for-furniture>

Finish: Polyurethane (PU) castor wheels
Manufacturer: GBL

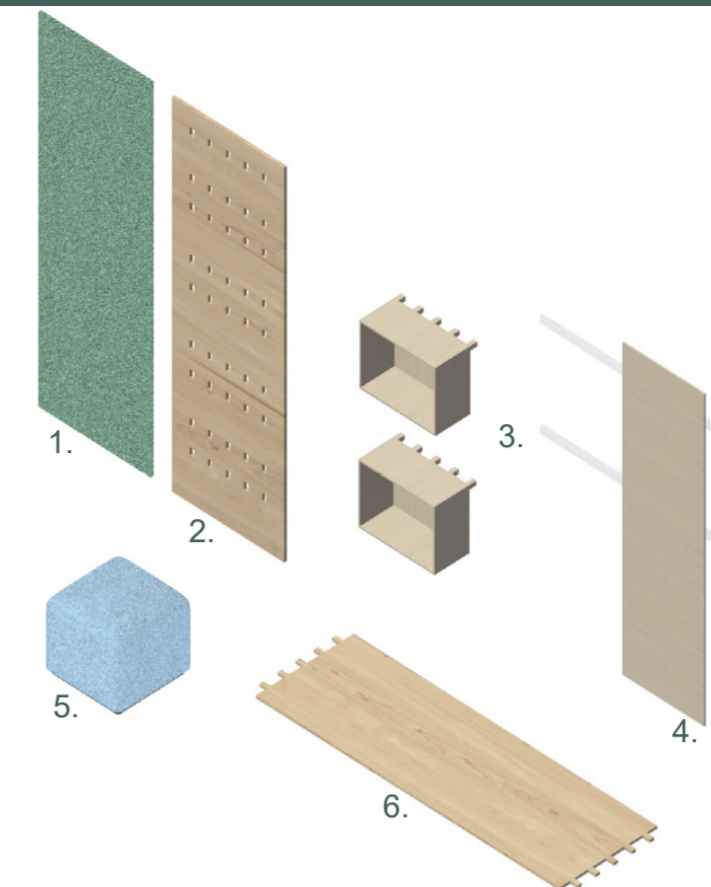

FURNITURE ACCESSORIES:

- | | |
|-------------------|-------------|
| 1. C Frame. | 4. D Frame. |
| 2. A, B, D Frame. | 5. C Frame. |
| 3. D Frame. | 6. B Frame. |

COMMUNITY CUBE:

These Cube structures are adaptable furniture that allow the community to take control of a space and how it is utilised. People can use the accessories to adapt the square frame for different applications to empower users and encourage engagement. The frames are designed to be easily maneuvered and enable them to function as a book shelf, seating area, and exhibition spaces with minimal effort. The materials used are easy to source, replace and adapt. They are hard wearing, light weight, with acoustic dampening qualities, and comfortable hardwearing finishes.



A FRAME



B FRAME



C FRAME

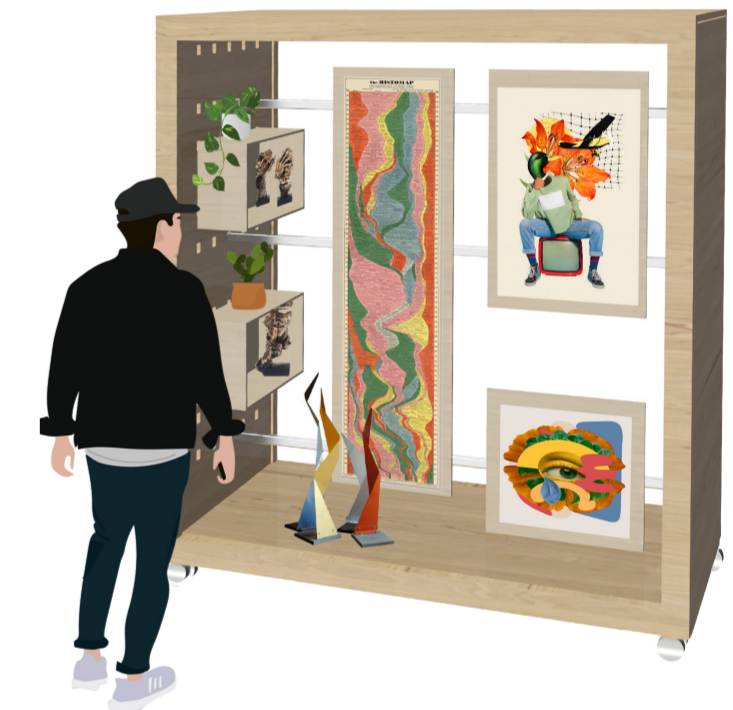

D FRAME

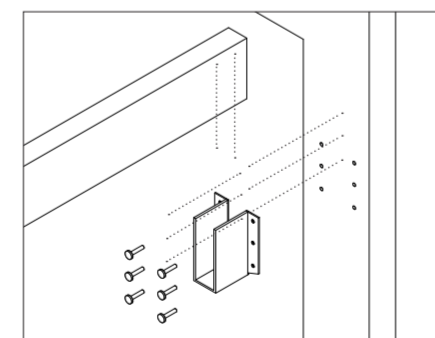

DETAILED AXONOMETRIC Furniture Frame

1. Screw to attach timber frame into timber support beam.
2. Plywood Frame 18mm thick, H2200mm X W2200mm.
3. Timber support beam 30mm thick, W750mm X H80mm.
4. Mini multi-truss hanger bracket, 1.5mm thick galvanised steel.
5. Industrial castor wheels, casters come with Steel plate and double ball bearings swivel head with dual locking.
6. Timber 50mm thick, H160mm X W750mm.
7. Timber 30mm thick, H50mm X W750.

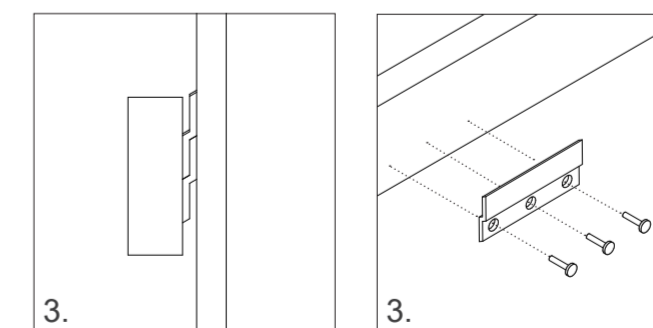
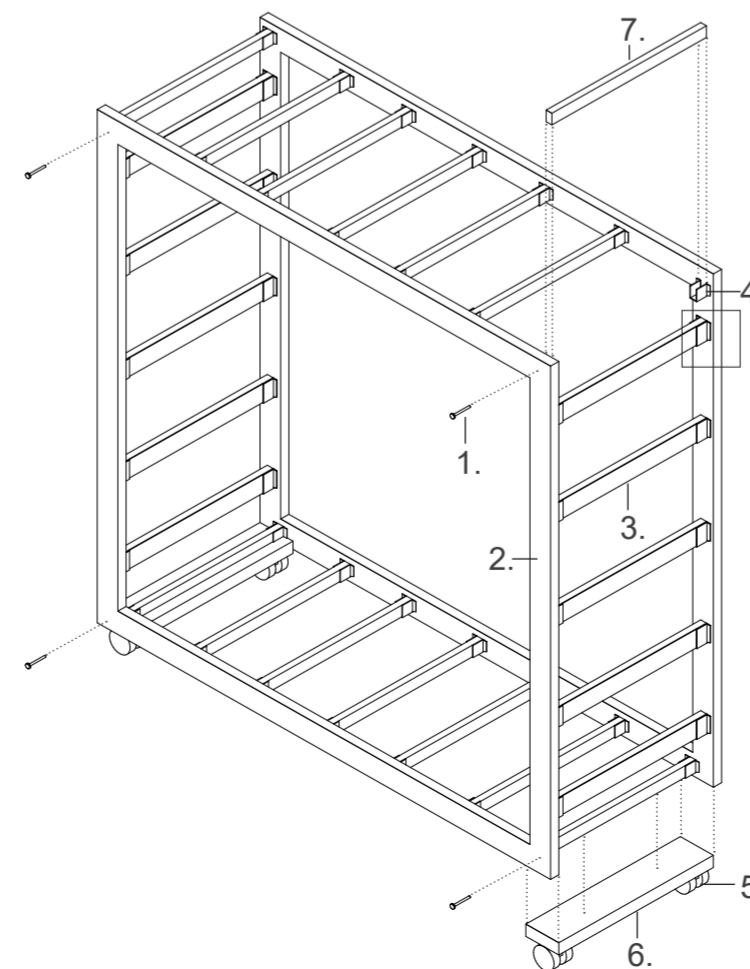

DETAILED AXONOMETRIC Furniture Frame Panelling

1. Screw to attach panel into timber.
2. Plywood panel, 15mm thick, W2200 X W750.
3. French cleat metal bracket.
4. Plywood panel, 15mm thick, W2200 X W750.

