

K23HE29MR02PD25MM205

G  
E  
N

TICKET NUMBER GA1 319

ADMISSION  
£90.50

A  
D  
M

EMP PRESENTS

Transcending

# ROCKETMAN

The Immersive Fusion of Theatre, Fashion & Exhibition

FRIDAY  
JULY 25  
2022

OLD BILLINGSGATE, LONDON

1 Old Billingsgate Walk (Riverside, 16 Lower Thames  
St, London EC3R 6DX

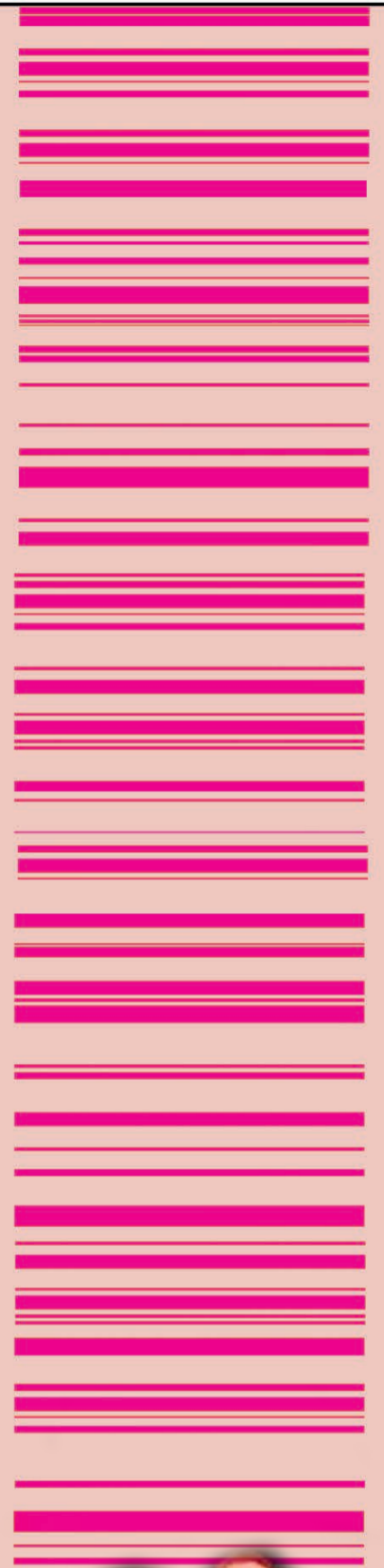

PRICE £90.50  
S/C £2.75  
Total £93.25



DRS 7pm  
FRIDAY JULY 25 2022

GA ADULT

U16S WITH ADULT



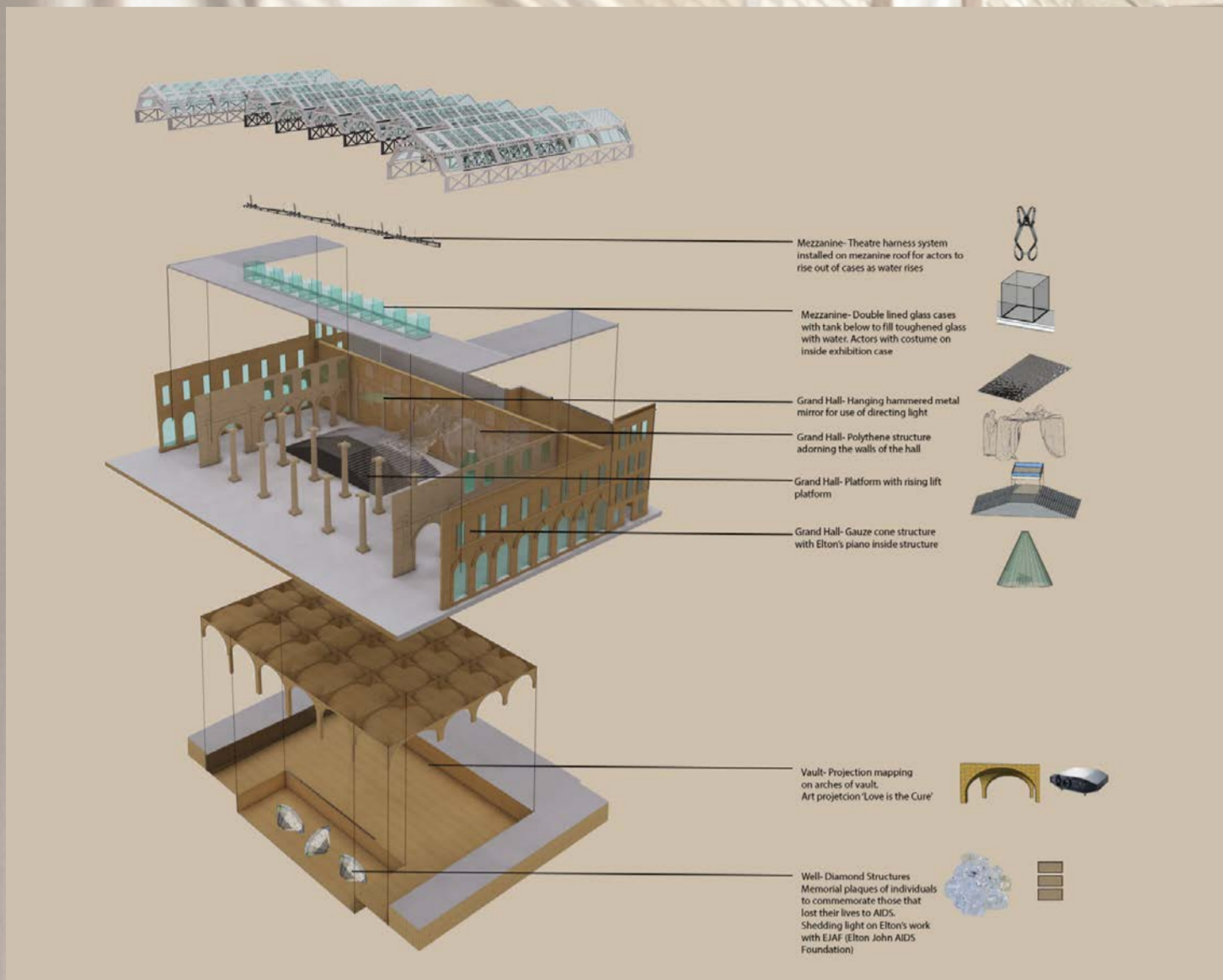

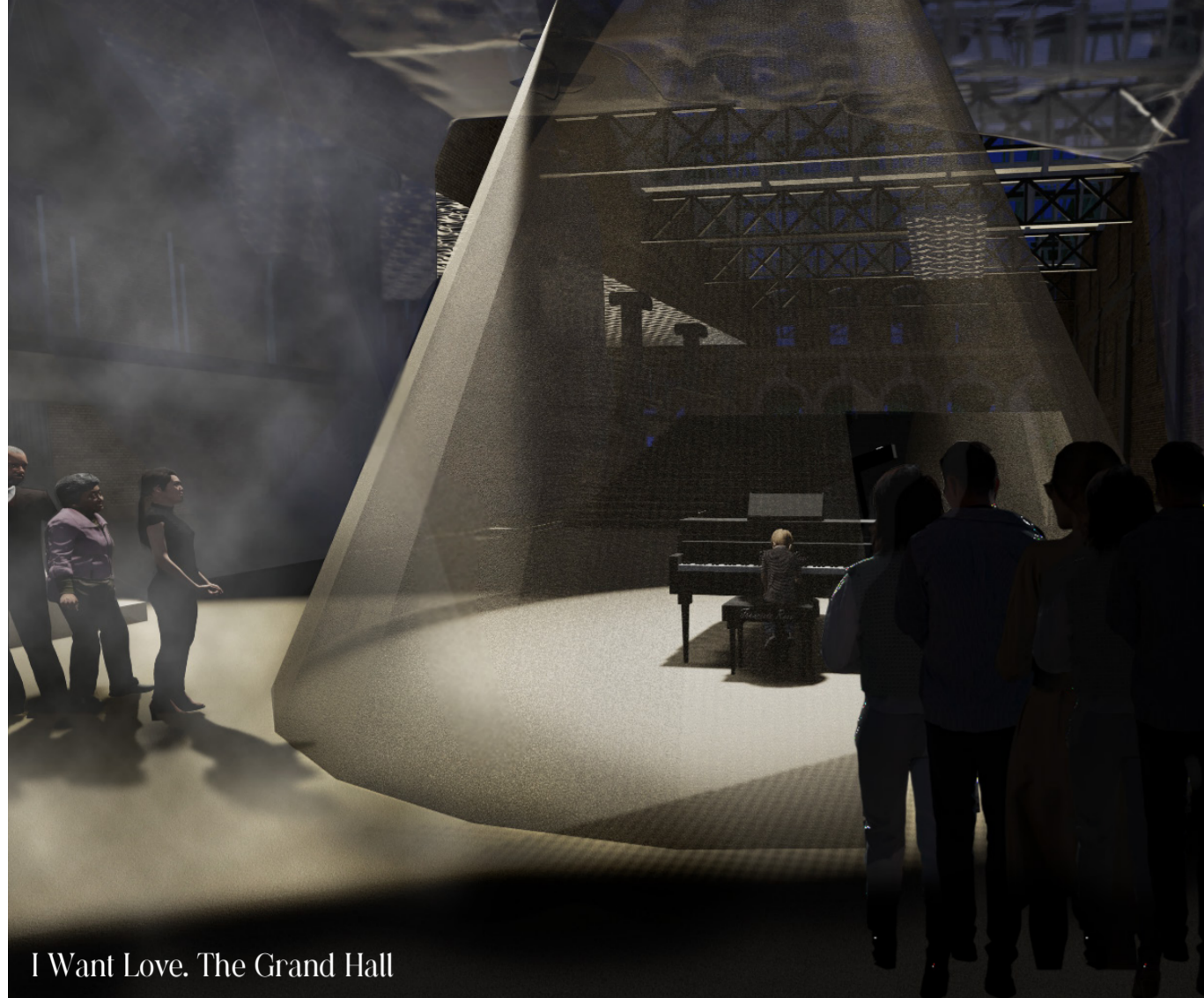

I Want Love. The Grand Hall



New Rule Book For Living. The Grand Hall



No Matter How Insane, Just Do It. The Grand Hall



My Life Is Like A Yoyo. My Sense Of Values Was Burried Under My Self Distruction. The Grand Hall



The Hlgh Bottom. Mezzanine



How Can I Be At Rock Bottom When I Am Already On Top Of The World? Mezzanine

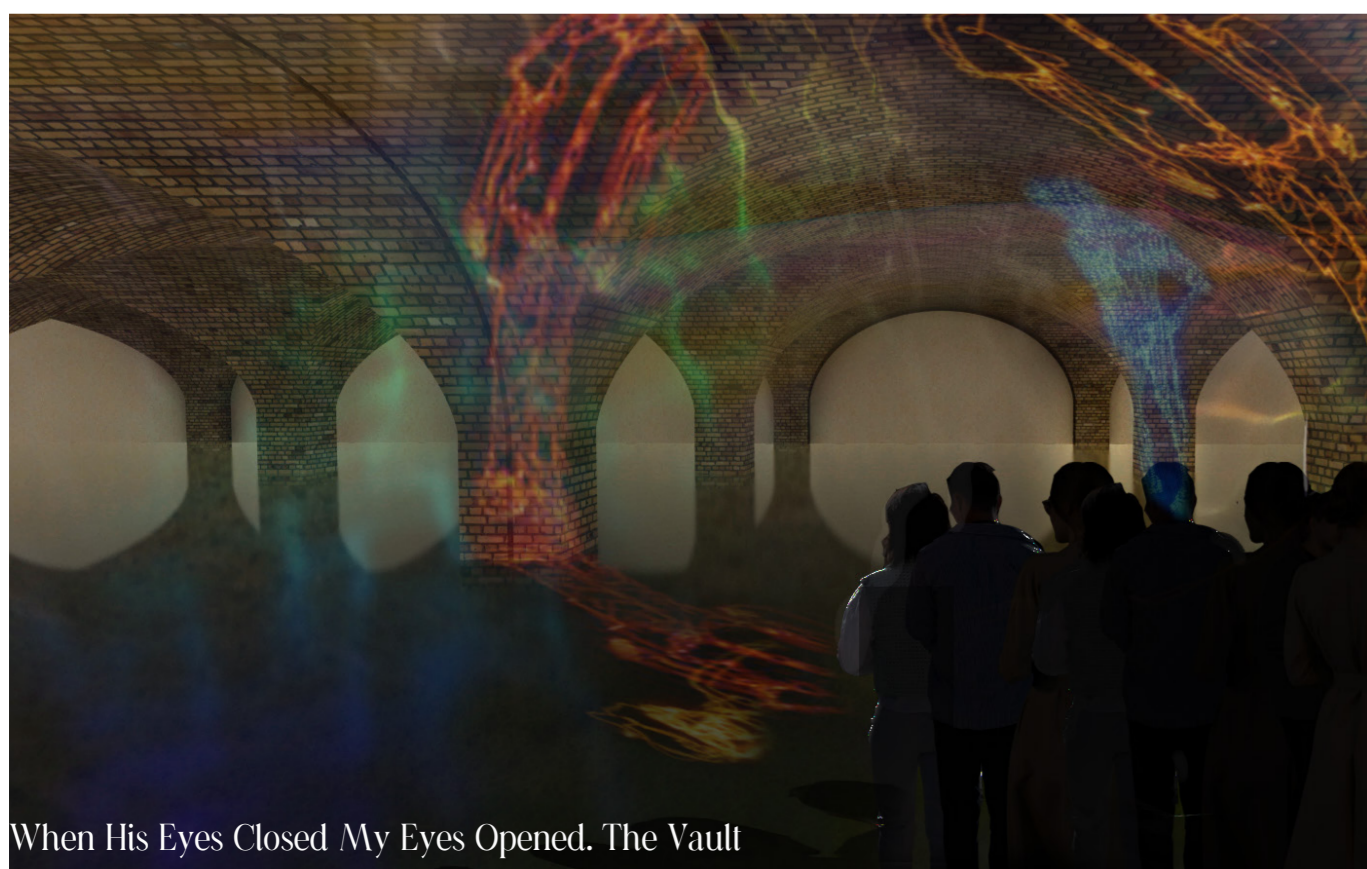

When His Eyes Closed My Eyes Opened. The Vault



Friendship Was The Catalyst To Help Me Change My Life. The Vault



Candle Burnt Out But Legend Never Will. The Well

The scene for theatre, fashion and exhibition has followed the same rules for some time, and now it seems time to see a progression. The aim of this major project is to fuse these three theatrical elements to create an unseen world for the performative and create arts world. This will be explored through the story of the iconic musical legend Elton John and the musical based on his life, Rocketman. This is a story that has not been seen in theatres and explores themes that challenge the norms, and highlights topical subjects such as drugs, addiction, love, homosexuality, therapy and fashion. This celebration and journey will aid the underlying aim to design for conversation with thrills, vulnerability charisma and pathos. This transformational concept does not deny history just symbolically transforms it.

Access to Video  
<https://youtu.be/nxV0gIPZyF0>

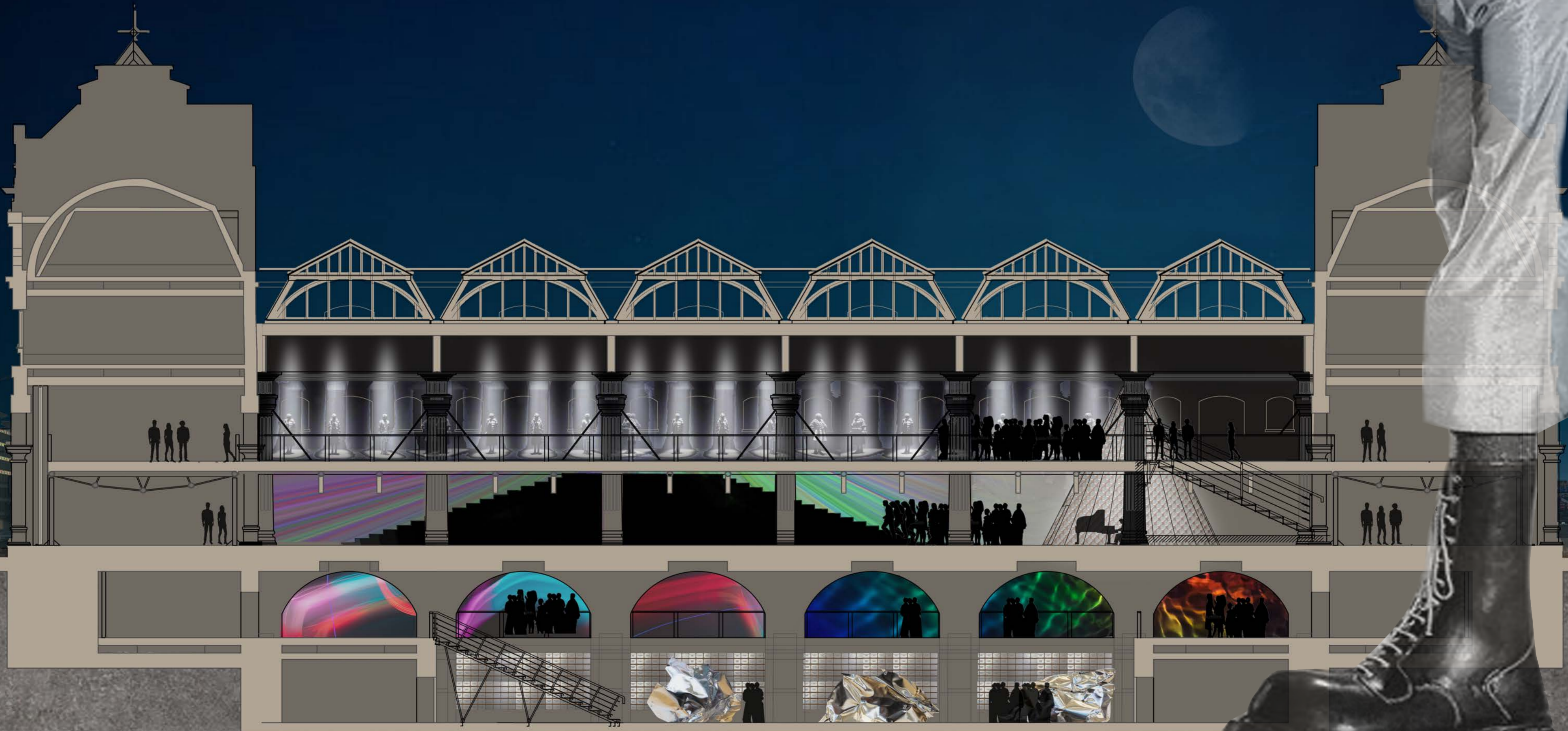

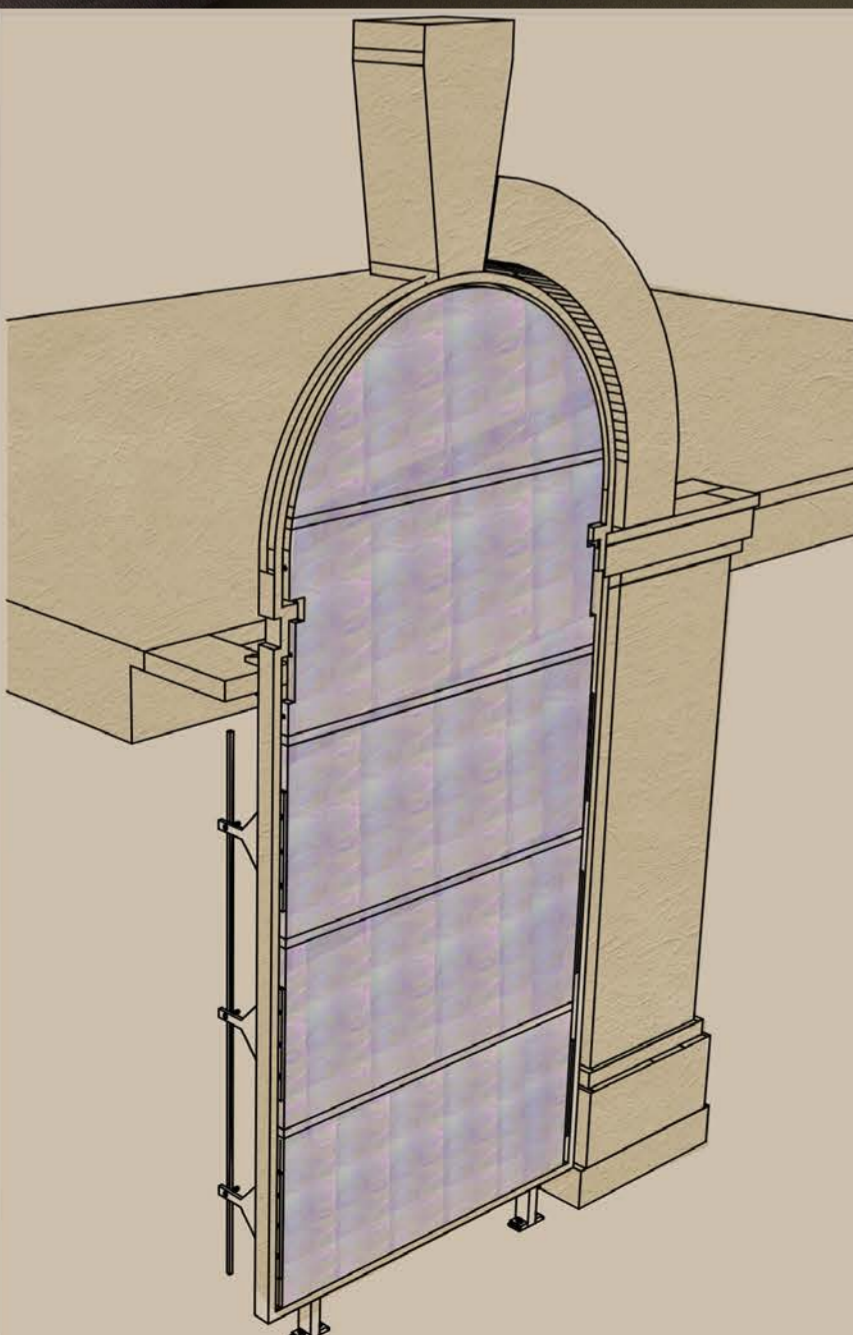
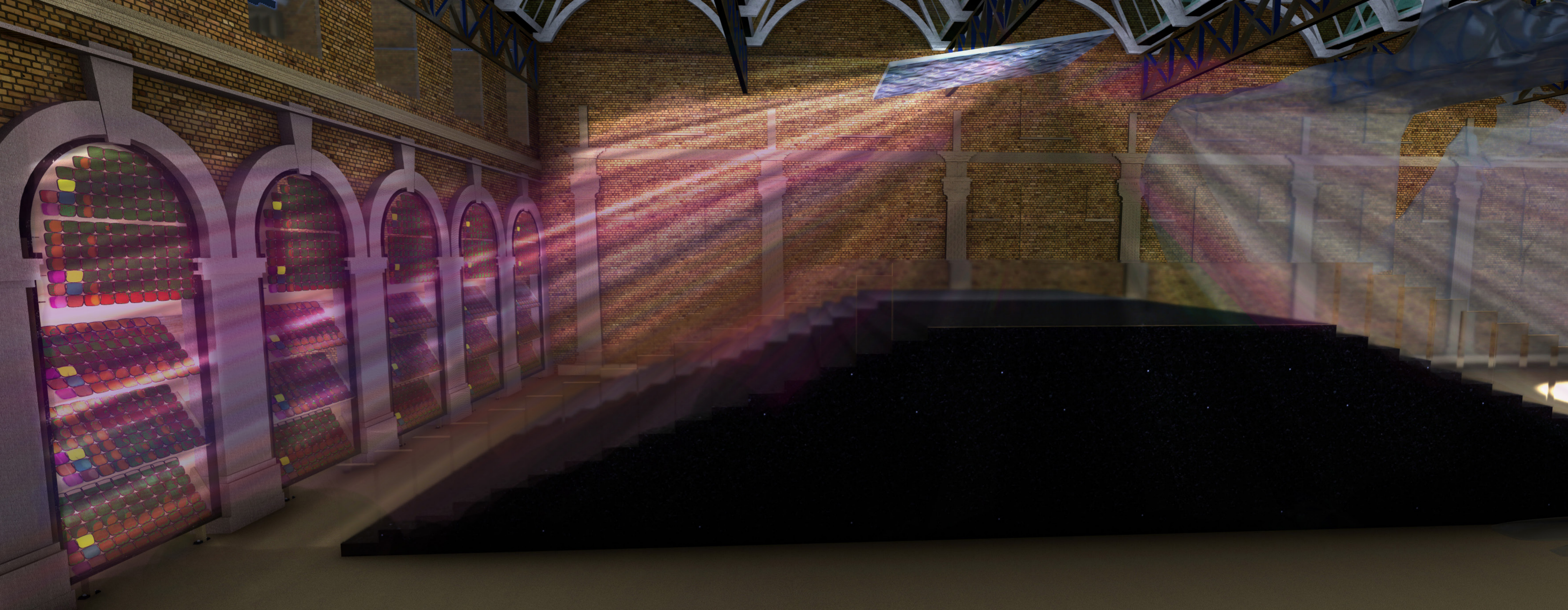

Arch Installation 1:50



Arch Installation 1:50

1. Leg Detail of Steel Frame to Floor
2. Clamp Attachment of Steel Frame to Mezzanine Floor
3. Top Two Static Resin Panel Fixings to Steel Frame
4. Lower Three Rotating Resin Panel Fixings and Manual Pivot Mechanism and Lighting Diagram
5. Pivot System Fixing
6. Dichroic Film Covered Lenses Set in Resin Panels

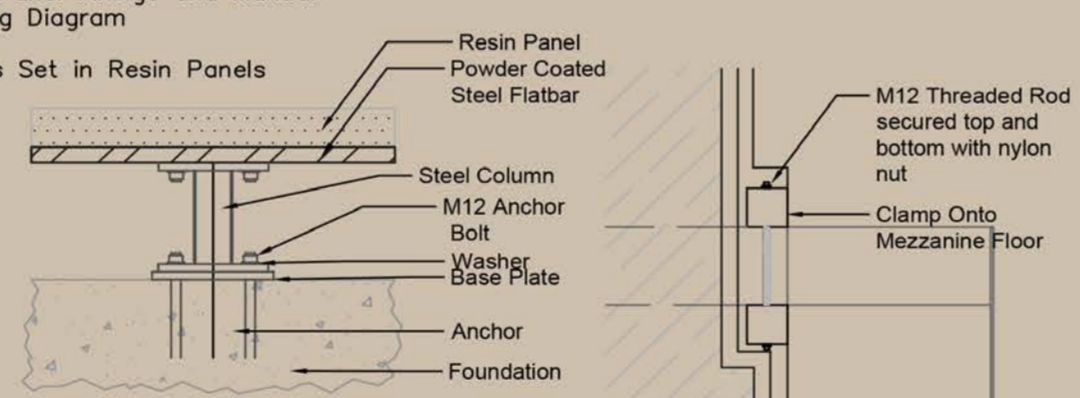

1. Section Leg Detail 1:10

2. Frame Mount, Mez Floor Elevation

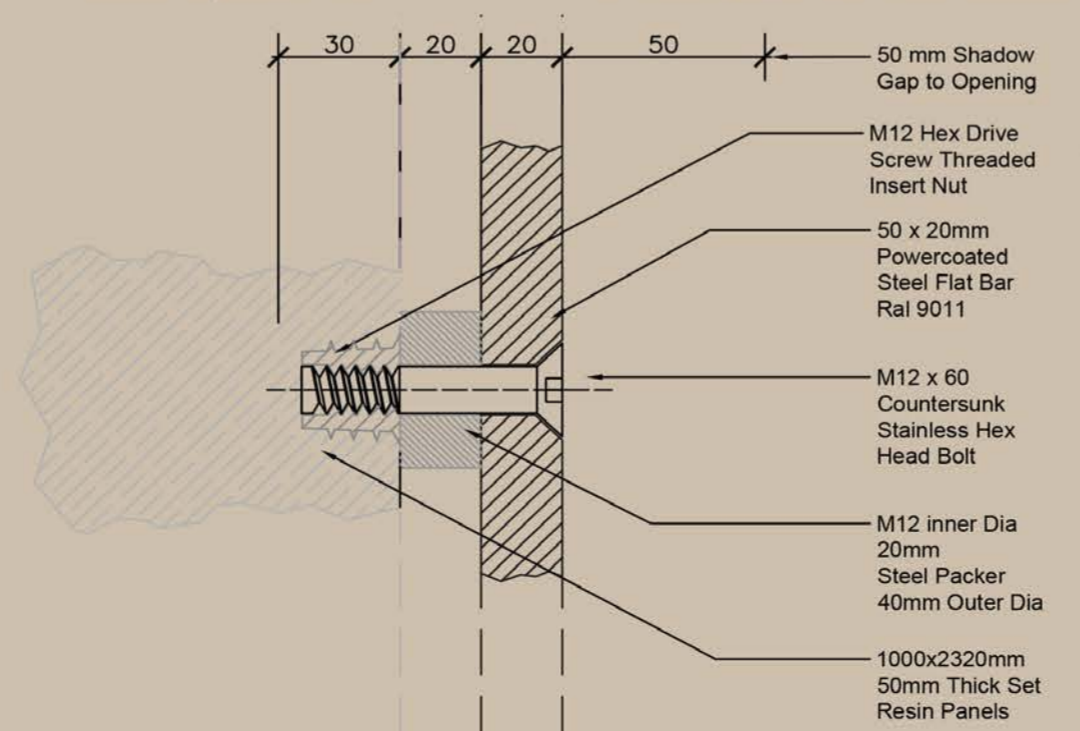

3. Static Resin Panel Fixings 1:2

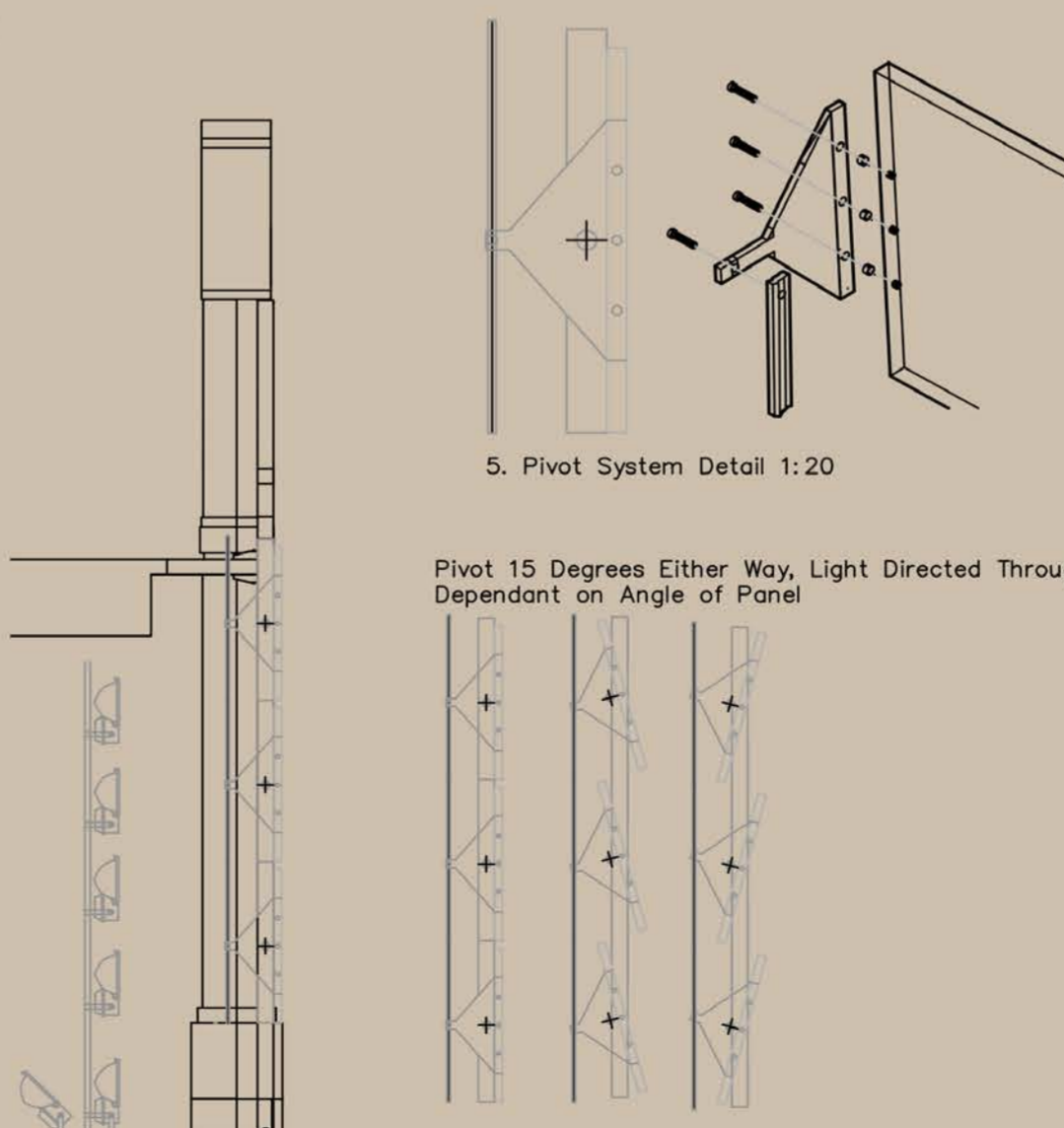

5. Pivot System Detail 1:20

Pivot 15 Degrees Either Way, Light Directed Through Panels Dependant on Angle of Panel

4. Pivot System Detail With Relevant Flood Lighting 1:50

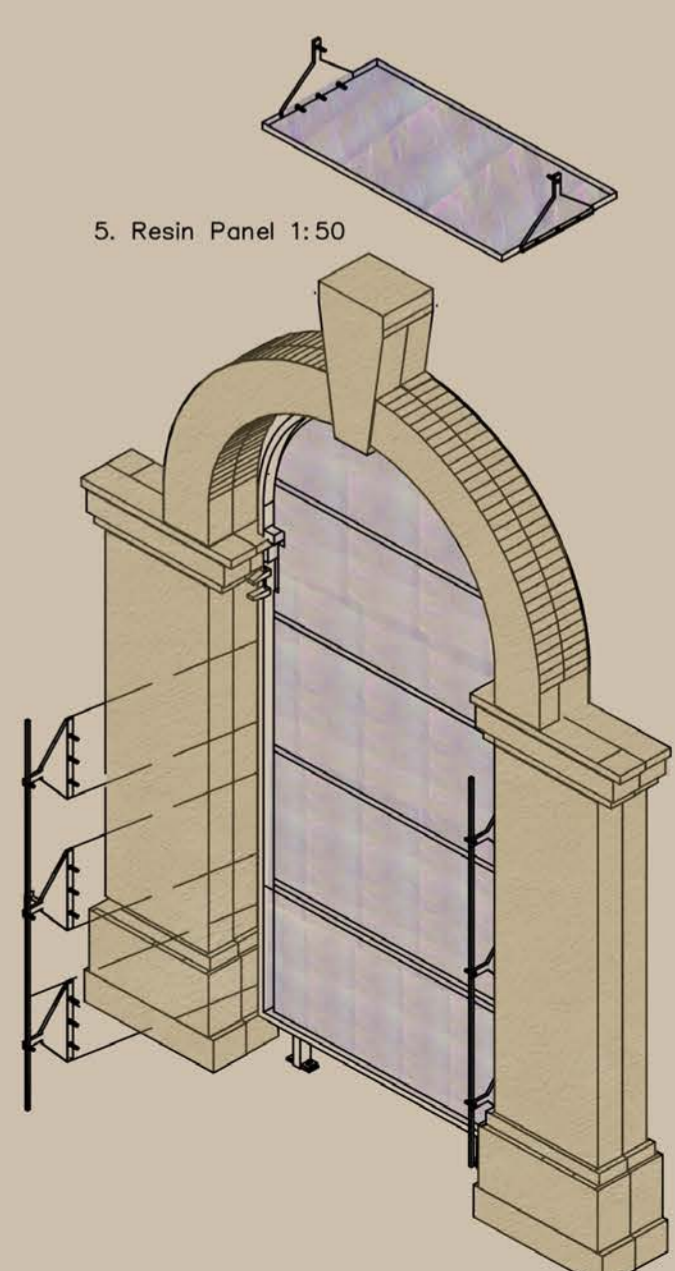

5. Resin Panel 1:50