

BYCATCH

MAJOR PROJECT

Site:

- Lochmaddy, North Uist, Scotland

Brief:

- For my Major Project, my task was to complete an in depth project package from concept, spatial/master planning, a focused major space and detail design. I chose a derelict building on the edge of a small fishing village where I grew up as my site.

My aspiration is that this design will positively impact North Uist's people by supporting local traditions, respecting the natural environment, strengthening industries and creating jobs. This design should bring a fresh and inspiring lease of life to the location whilst establishing Lochmaddy as a hub for ocean waste recycling.

Concept:

- Every year, around 8 million tonnes of litter reaches the ocean. The beaches and shores of North Uist are being badly damaged by this, littered after every storm. Despite being portrayed as perpetrators in the ocean plastic pandemic, the fishing industry is increasingly harmed by ocean waste through a significant loss of revenue, damage to vessels, equipment, and by loss of time spent fishing.

Efforts are being made all around the world to clean up ocean waste, and this is important. Bycatch aims to clean up the ocean and discover ways to recycle and re-purpose waste products whilst changing perceptions and encouraging people to rethink how they see materials such as plastic.

Community is at the heart of island life. This project should treat the community as an asset by appreciating fishermen's unique position with a vast knowledge of the ocean and unique access to remote areas.

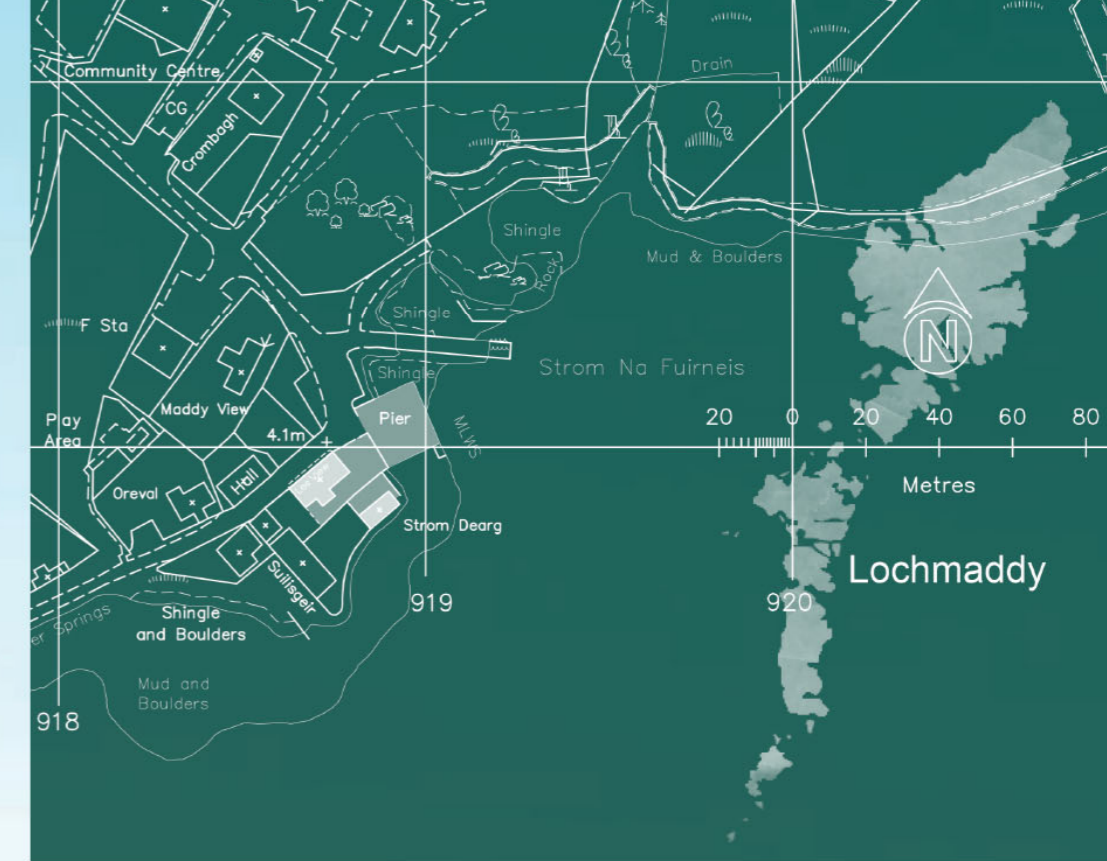

01

02

03

04

05

06

07



Site Photo Sky View

BYCATCH location

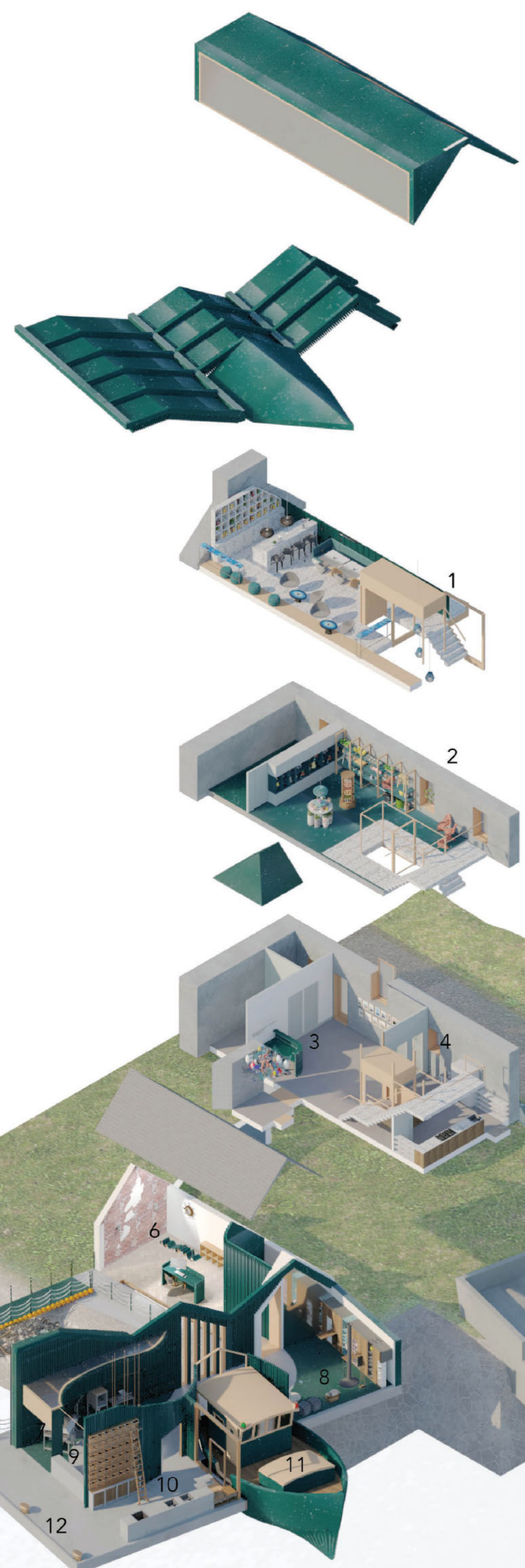

1. CATCH CAFE
2. BYCATCH SHOP
3. RECEPTION
4. KITCHEN
5. FISHING PIER
6. WORKSHOP WELCOME AREA
7. THE OCEAN CLEANUP PASSIVE SYSTEM
8. FINISHING TOUCHES WORK SPACE
9. MAIN WORKSHOP
10. WASH/SORT/SHRED WORK SPACE
11. PLASTIC FISHING BOAT
12. FISHERMEN PLASTIC LANDING

Exploded isometric



Catch Cafe



BYCATCH Shop



Reception



The Ocean Cleanup Pontoon

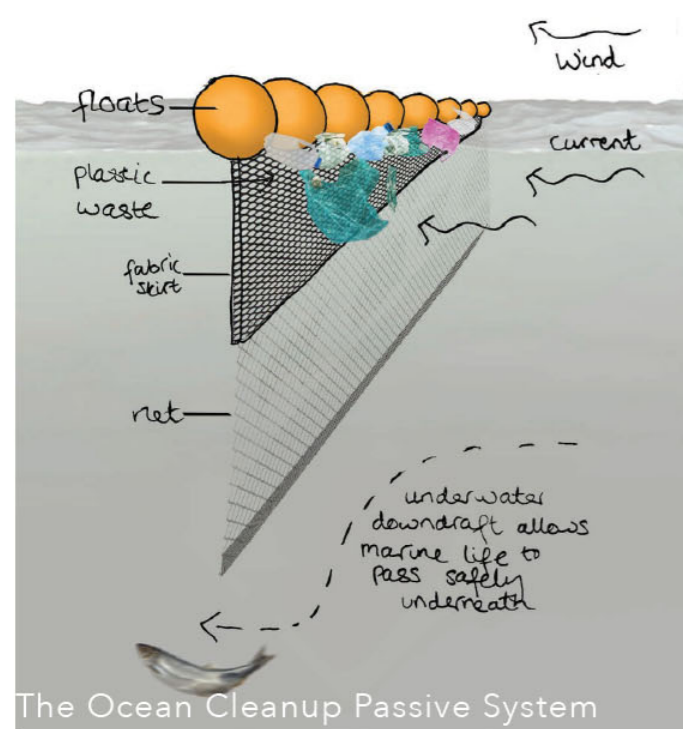

The Ocean Cleanup Passive System

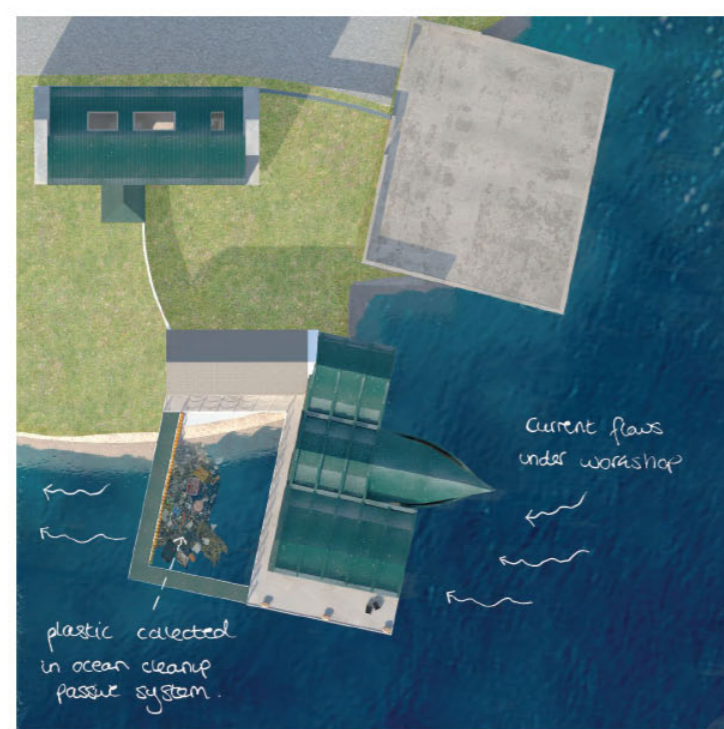

plastic collected in ocean cleanup passive system.



"We love our island. Our industries really heavily on tourism and the Outer Hebrides are known for their beautiful beaches and clear waters. It is disheartening when we go down to the beach and the place is littered with ocean waste. It is only getting worse. Something needs to change."

- Community Cleanup Group

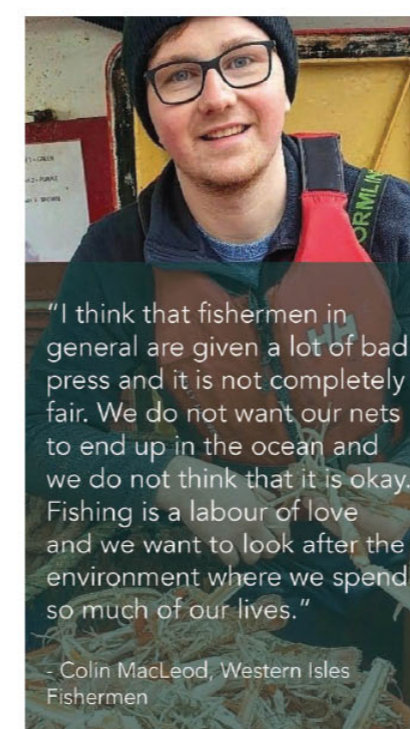

"I think that fishermen in general are given a lot of bad press and it is not completely fair. We do not want our nets to end up in the ocean and we do not think that it is okay. Fishing is a labour of love and we want to look after the environment where we spend so much of our lives."

- Colin MacLeod, Western Isles Fishermen



Workshop Welcome Space



Ground Floor Plan 1:1000

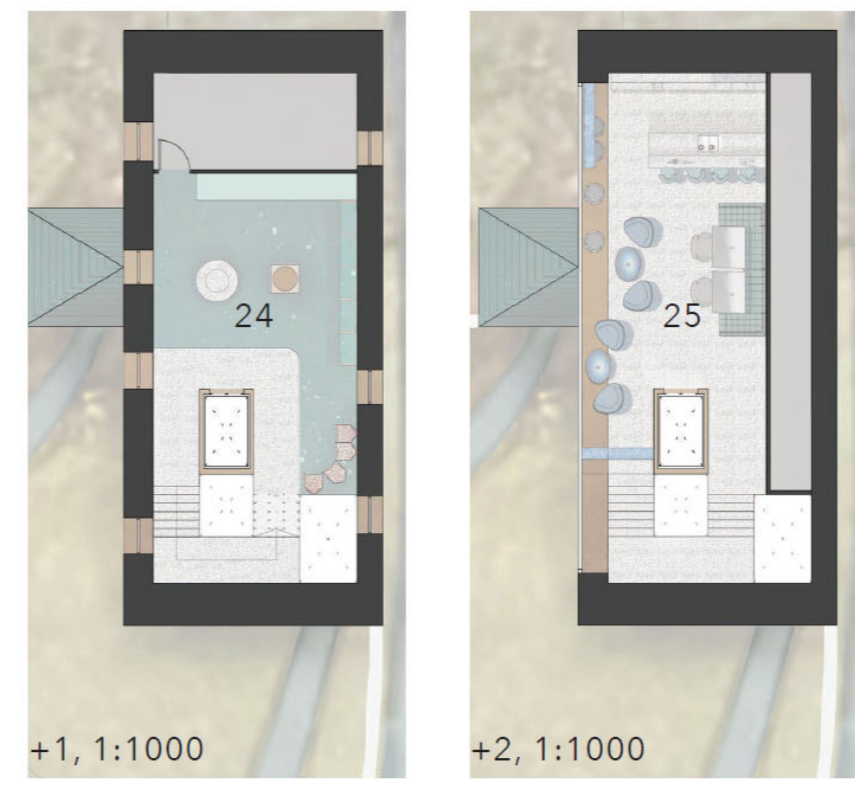

+1, 1:1000

+2, 1:1000

1. Ocean Cleanup & Fisherman Workshop Entrance
2. Plastic Sorting Sink
3. Workshop Entrance
4. Washing Sink
5. Shredder
6. Double Sided Shredded Plastic Storage
7. Workshop Table
8. Sheetpress
9. Injection Mould
10. Compressor
11. Extruder
12. Entrance to Plastic Fishing Boat
13. Plastic Fishing Boat
14. Finishing Touches Work Space
15. Fireplace for Comfort and Stamping
16. Toilets
17. Storage/Staff Areas
18. Welcome
19. Entrance to The Ocean Cleanup Walkway
20. Pontoon Walkway
21. The Ocean Cleanup Passive Cleaning system
22. Kitchen
23. Fishermen Entrance & Route to Kitchen
24. BYCATCH Shop
25. Catch Cafe



Finishing Touches Towards Reception

BYCATCH SEASONAL ARTIST EVENTS

MANDY BARKER
19 DECEMBER TO
20 MARCH

OPENING NIGHT
19/12/20 19:00

PLASTIC FISHING TRIPS
Every Thursdays & Saturday
at 10:00

WORKSHOPS
Every Thursday & Saturday
14:00

CLOSING NIGHT
20/03/21 19:00

Come along to our Opening and Closing Events to enjoy an array of local produce including drinks by **North Uist Distillery**, **Fresh Seafood** landed at our on site harbour and fresh baked goods from **MacLeans Bakery**

To Ensure that BYCATCH is Successful all year round, artists in residence will work at the centre for a full season.

Each artist will participate in lectures, plastic fishing trips, and workshops to **educate and inspire** visitors. At the beginning and end of each residency, BYCATCH will host an evening event, encouraging visitors to hear about the artists work whilst enjoying some local, seasonal food and drinks.

With harsh winter storms, ocean plastic becomes worse in North Uist so there will be more of a need for the workshop during the tourist 'off season' With each new artist bringing a fresh and exciting approach, it will **encourage community members to return.**



Plastic Fishing Boat Entrance

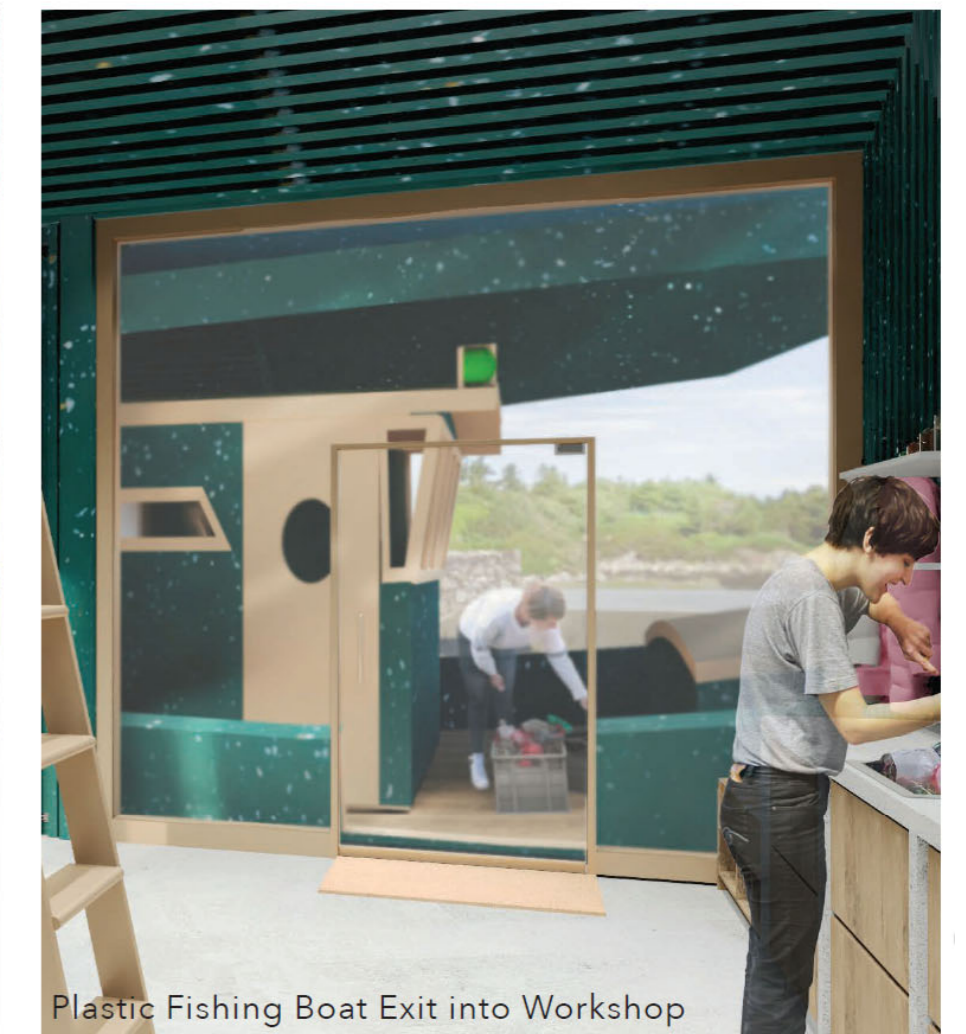

Plastic Fishing Boat Exit into Workshop



Workshop Entry Wash, Sort, Shred

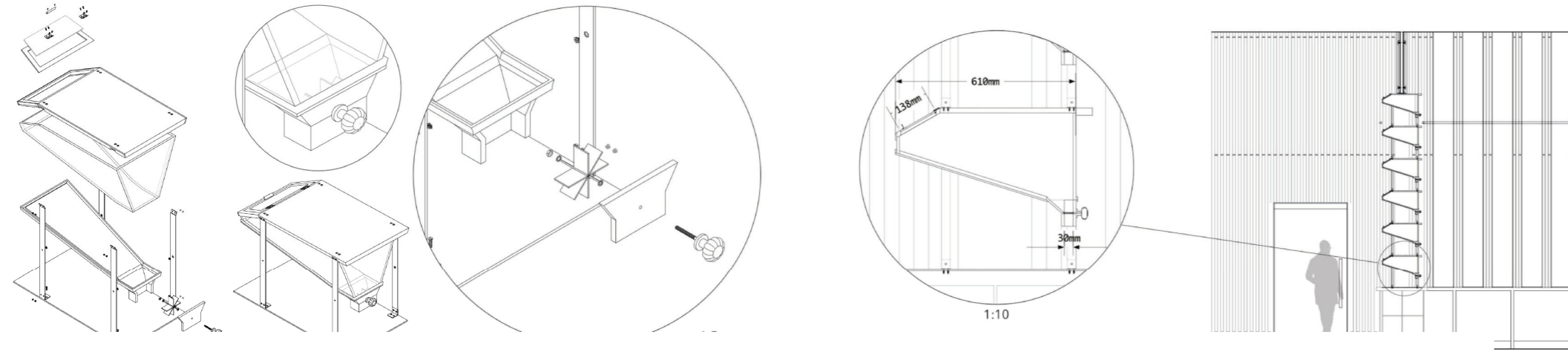

Main Workshop

1. Recycled Plastic Battens follow curve
2. Mounting Track Clips
3. Fixing Screw
4. Curved Mounting Track
5. Curved Plastic Backing
6. Curved Stud wall Frame
7. Main Interior Recycled Plastic Battens
8. Interior Mounting Track
9. Plastic Backing
10. Stud Wall
11. Recycled Plastic Insulation
12. Cavity
13. Breeze Blocks
14. Exterior Mounting Track
15. Exterior Recycled Plastic Battens
16. LED Light
17. Extraction Duct
18. Extraction Box with Fan and Filter
19. Extractor Wall Bracket

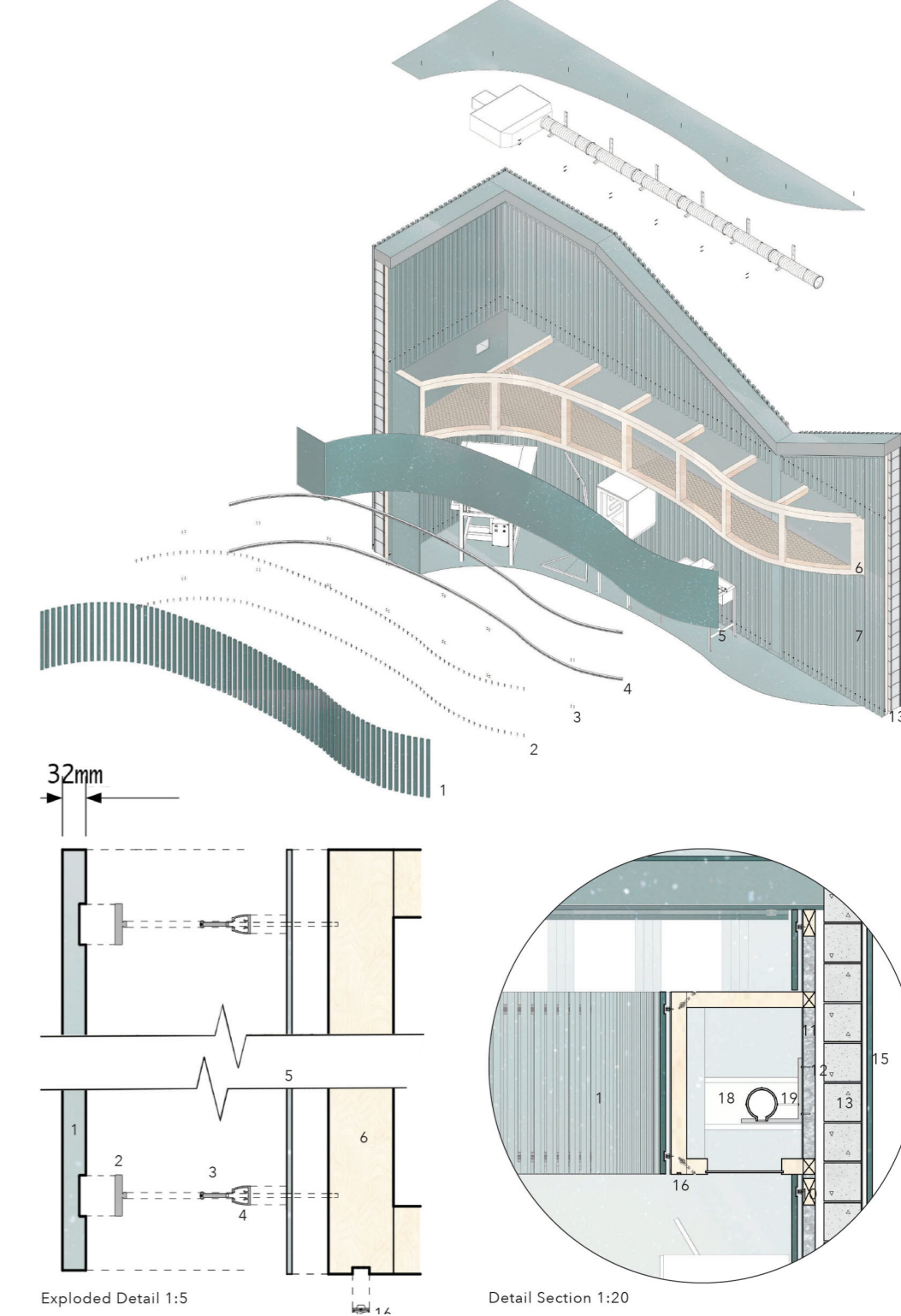

Exploded Detail 1:5

Detail Section 1:20

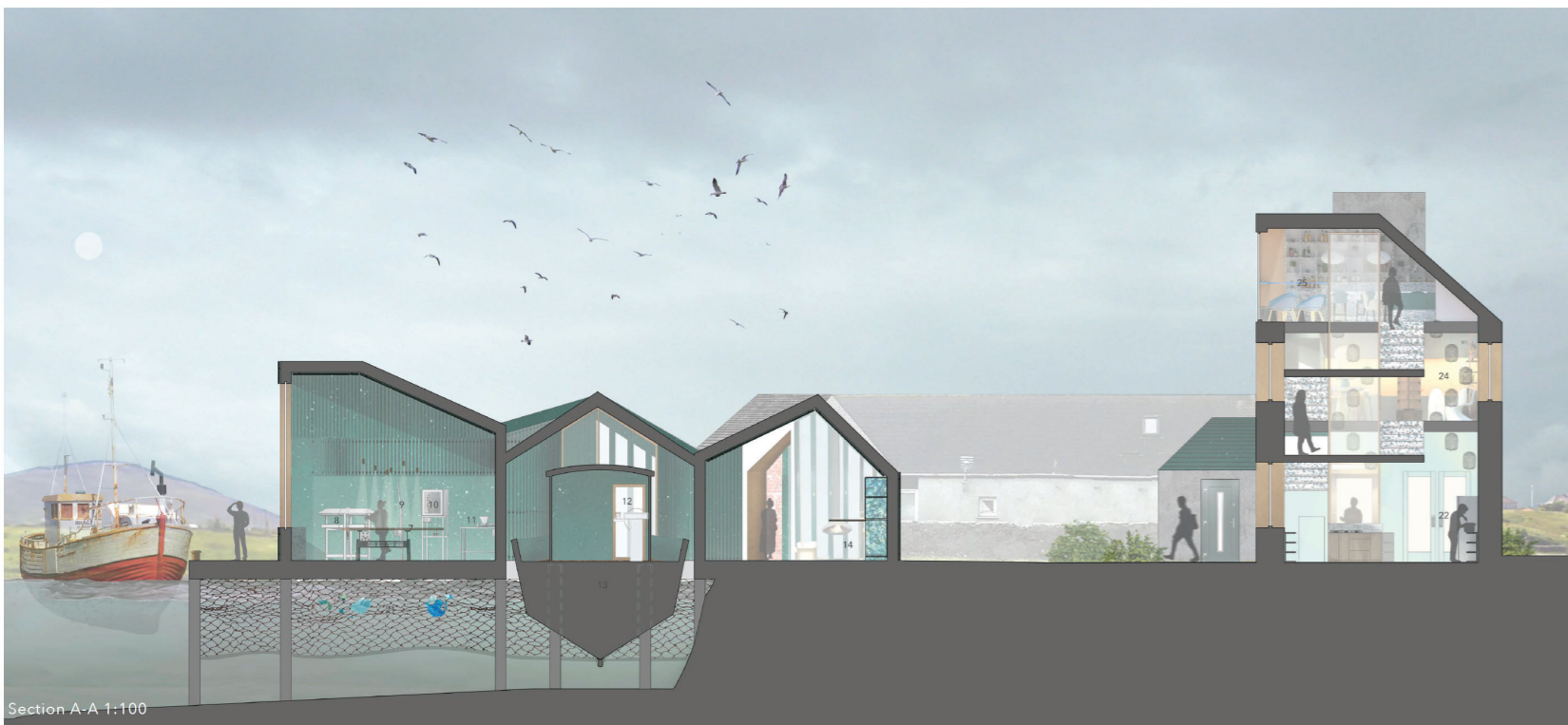

Section A-A 1:100



Section B-B 1:100

1. Ocean Cleanup & Fisherman
2. Workshop Entrance
3. Plastic Sorting Sink
4. Workshop Entrance
5. Washing Sink
6. Shredder
7. Double Sided Shredded Plastic Storage
8. Workshop Table
9. Sheetpress
10. Injection Mould
11. Compressor
12. Extruder
13. Entrance to Plastic Fishing Boat
14. Plastic Fishing Boat
15. Finishing Touches Work Space
16. Fireplace for Comfort and Stamping
17. Toilets
18. Storage/Staff Areas
19. Welcome
20. Entrance to The Ocean Cleanup Walkway
21. Pontoon Walkway
22. The Ocean Cleanup Passive Cleaning system
23. Kitchen
24. Fishermen Entrance & Route to Kitchen
25. BYCATCH Shop
26. Catch Cafe



Approach by Boat

01
02
03
04
05
06

Link to Project Video

<https://www.napierdegreeshow.co.uk/interior-spatial-design/ann-macleod>