

BRIEF:

‘A WORKPLACE THAT IS COOPERATIVE AS IT IS PRIVATE’

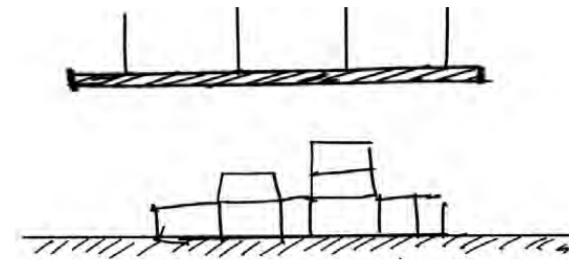



8:00 am

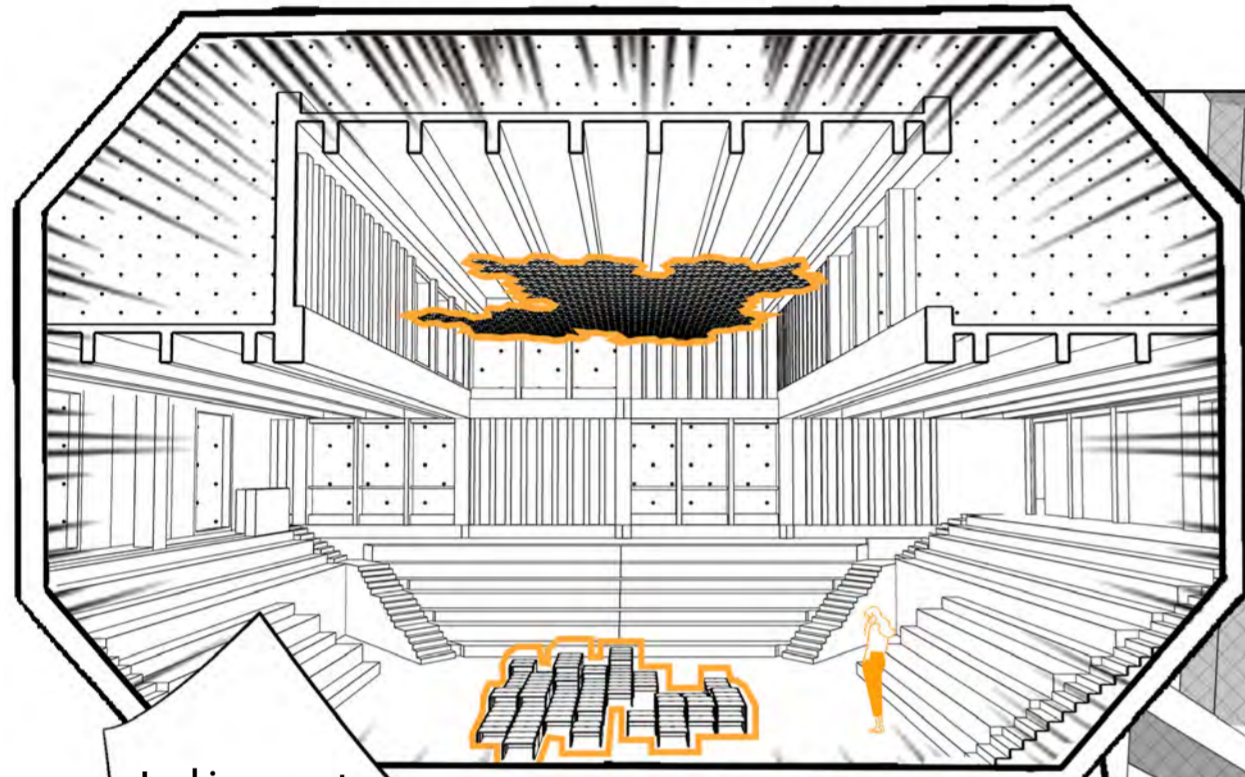

Looking up at the triangle hanging from the ceiling can have lighting effect! It's really nice to read a book here.

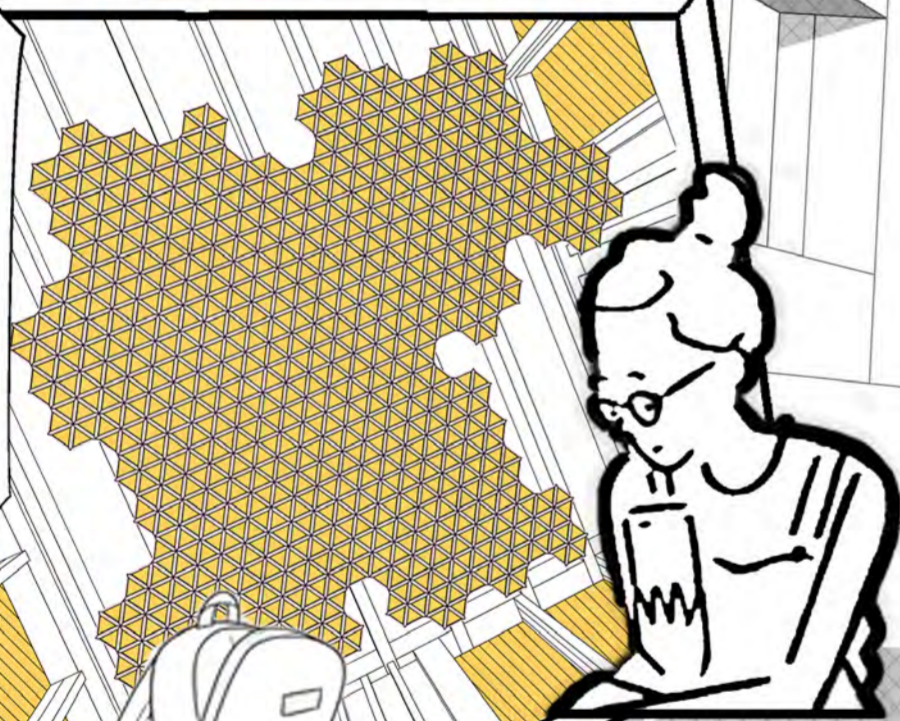

I heard that Town House has new and interesting changes, so go hurry to check it out in the morning!



This height is just enough for me to lean on, these boxes seem to be able to disassemble

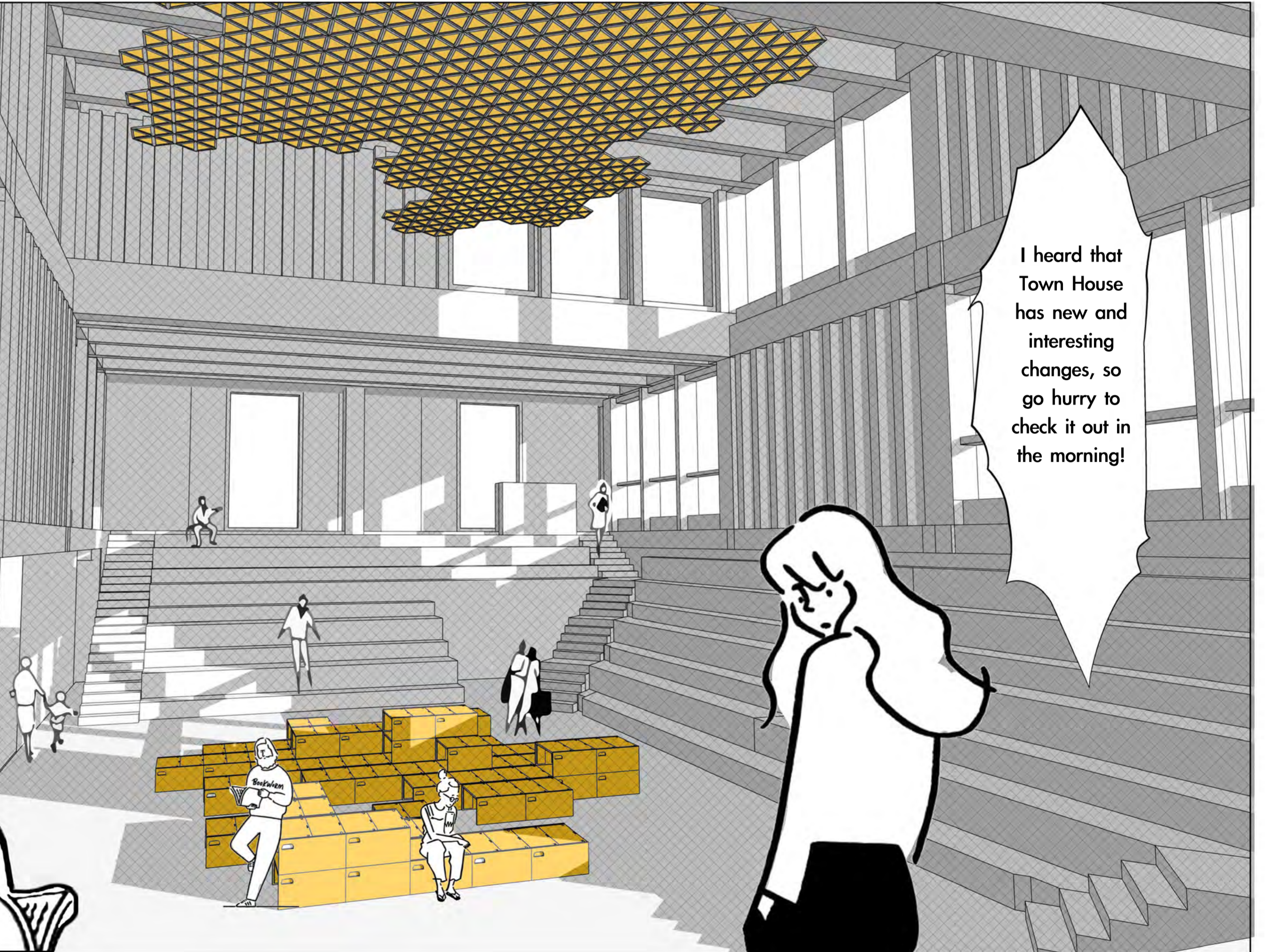
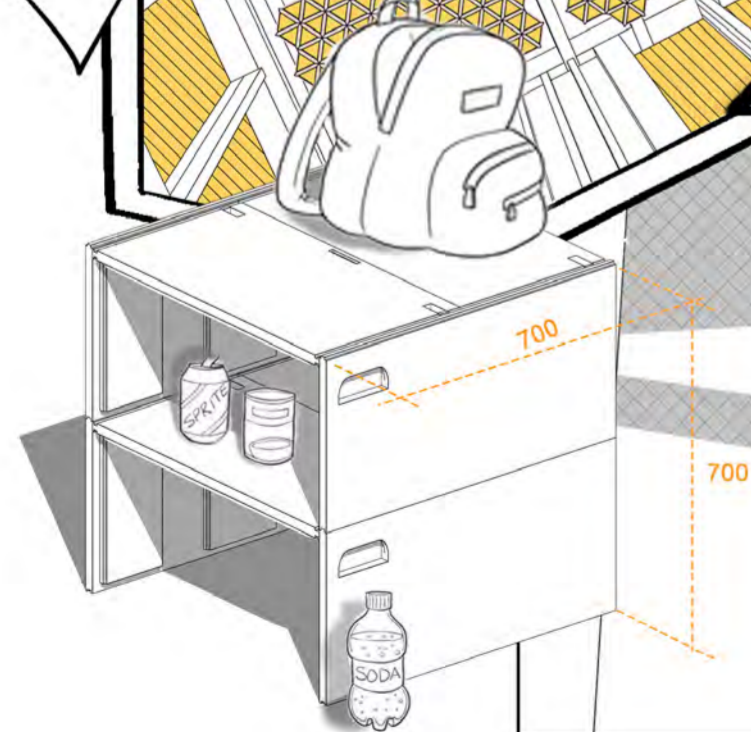

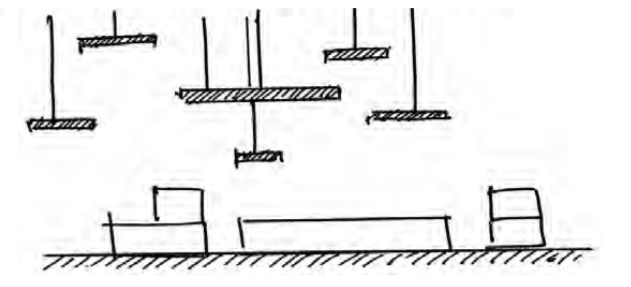

10:00 am--6:00 pm (State I)

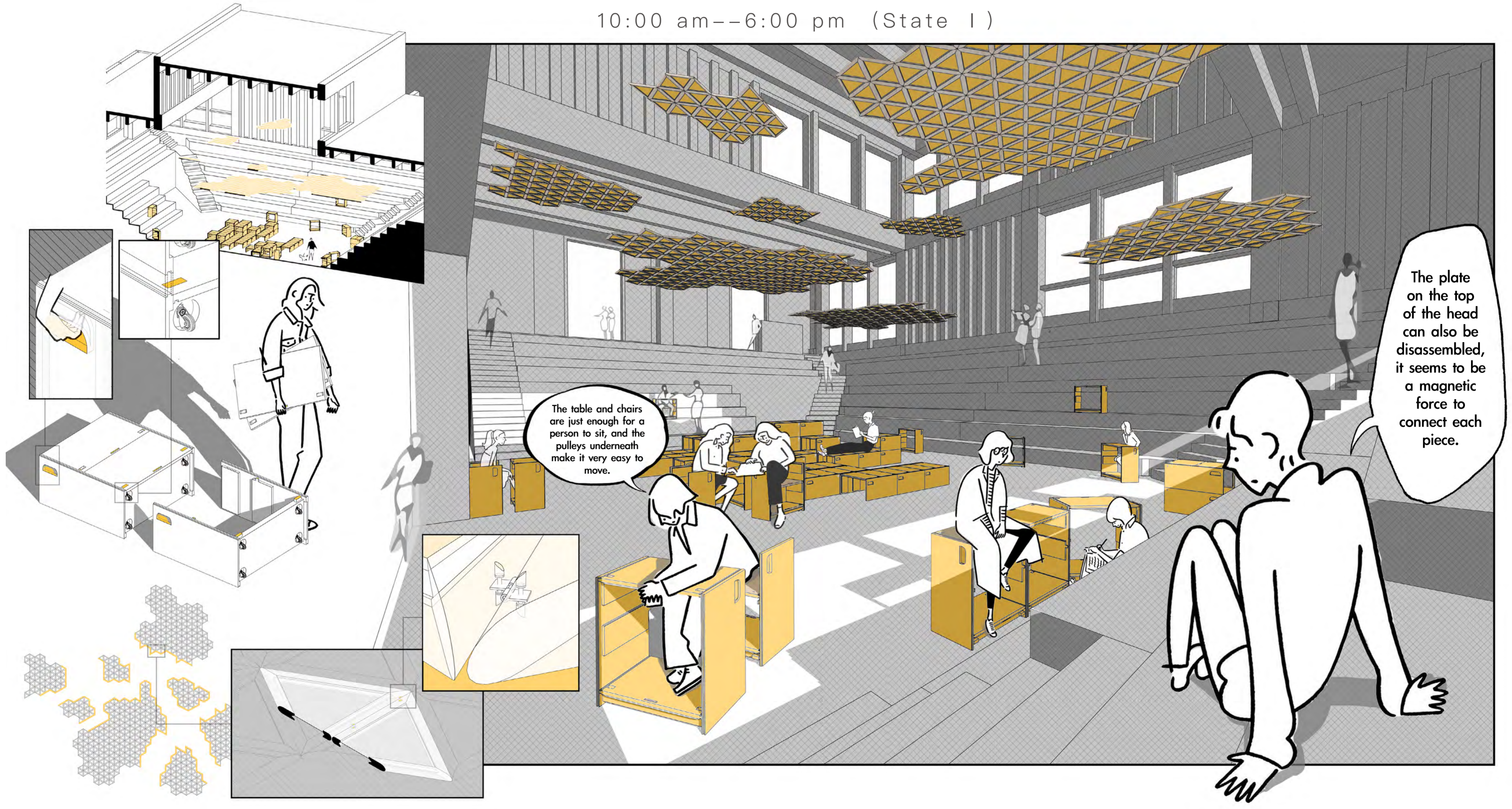

The table and chairs are just enough for a person to sit, and the pulleys underneath make it very easy to move.

The plate on the top of the head can also be disassembled, it seems to be a magnetic force to connect each piece.

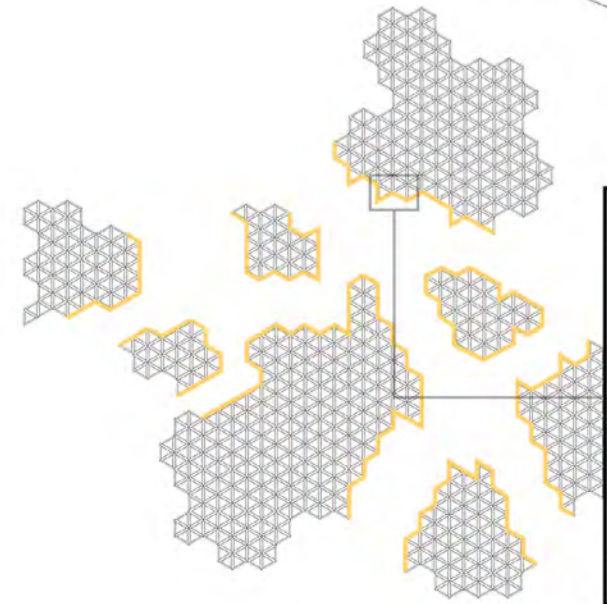
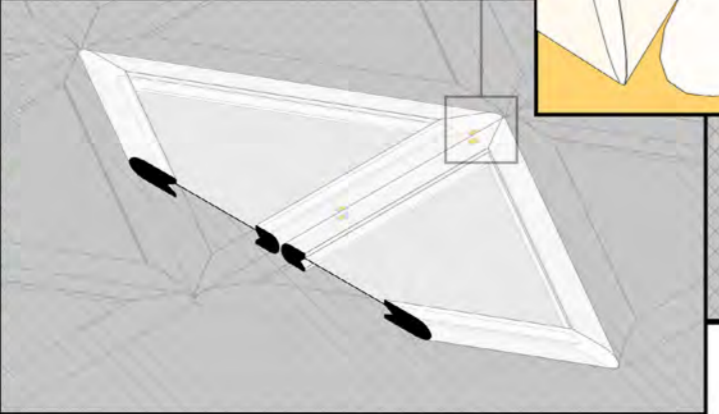
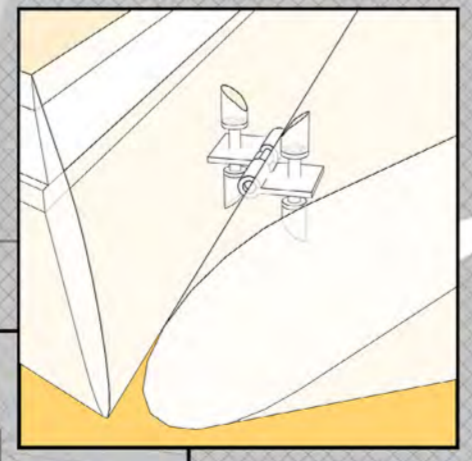

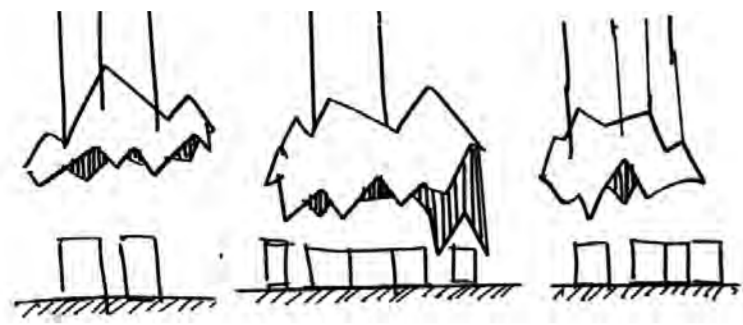

10:00 am--6:00 pm (State II)





Sketch model 1:20



Sketch model 1:10

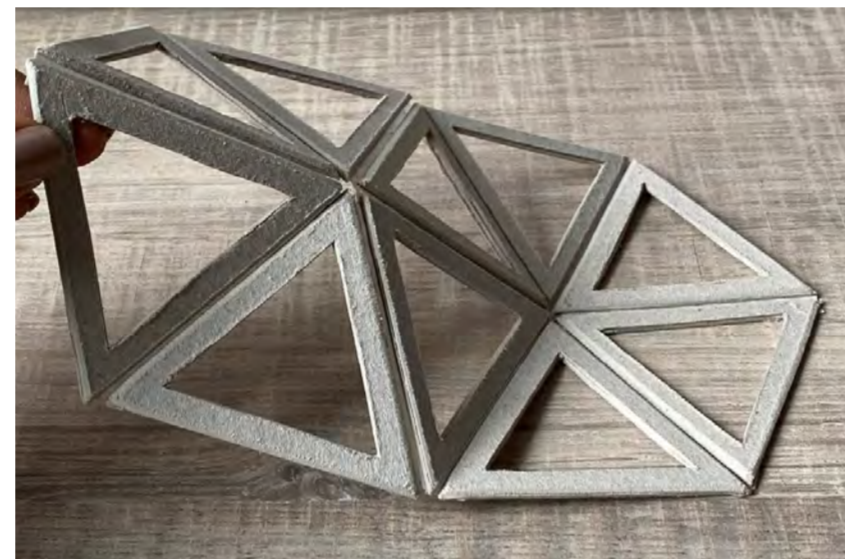

Sketch model 1:5



Sketch model 1:1

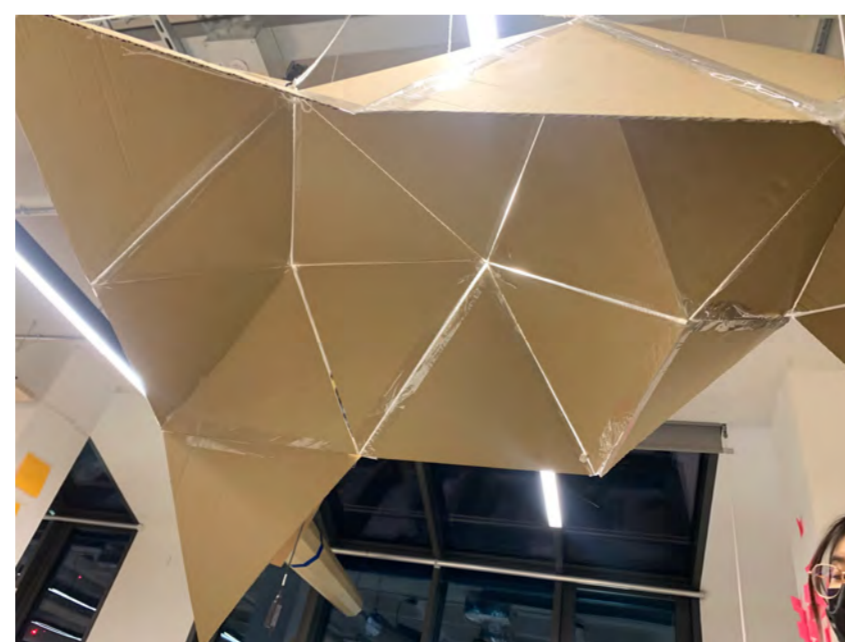

Detail Model



PRECEDENT STUDIES



VICTORIA 2 light

PROCESS SKETCHES

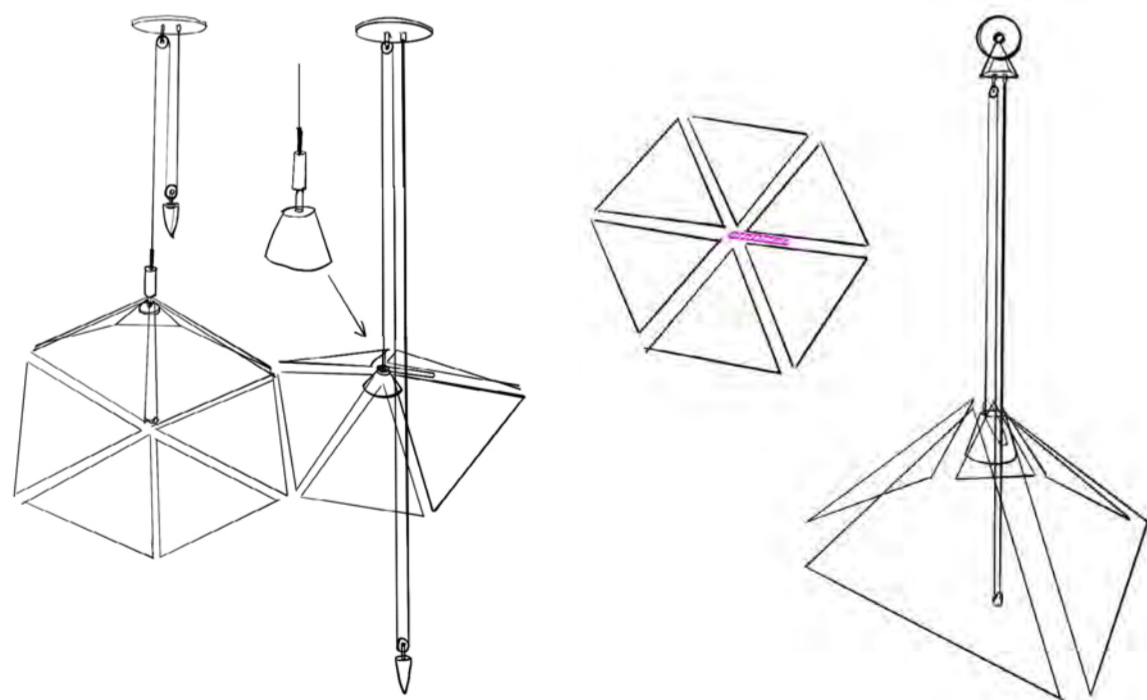

According to the structure of precedent, three pulleys are used to achieve the effect of sliding up and down and left and right.

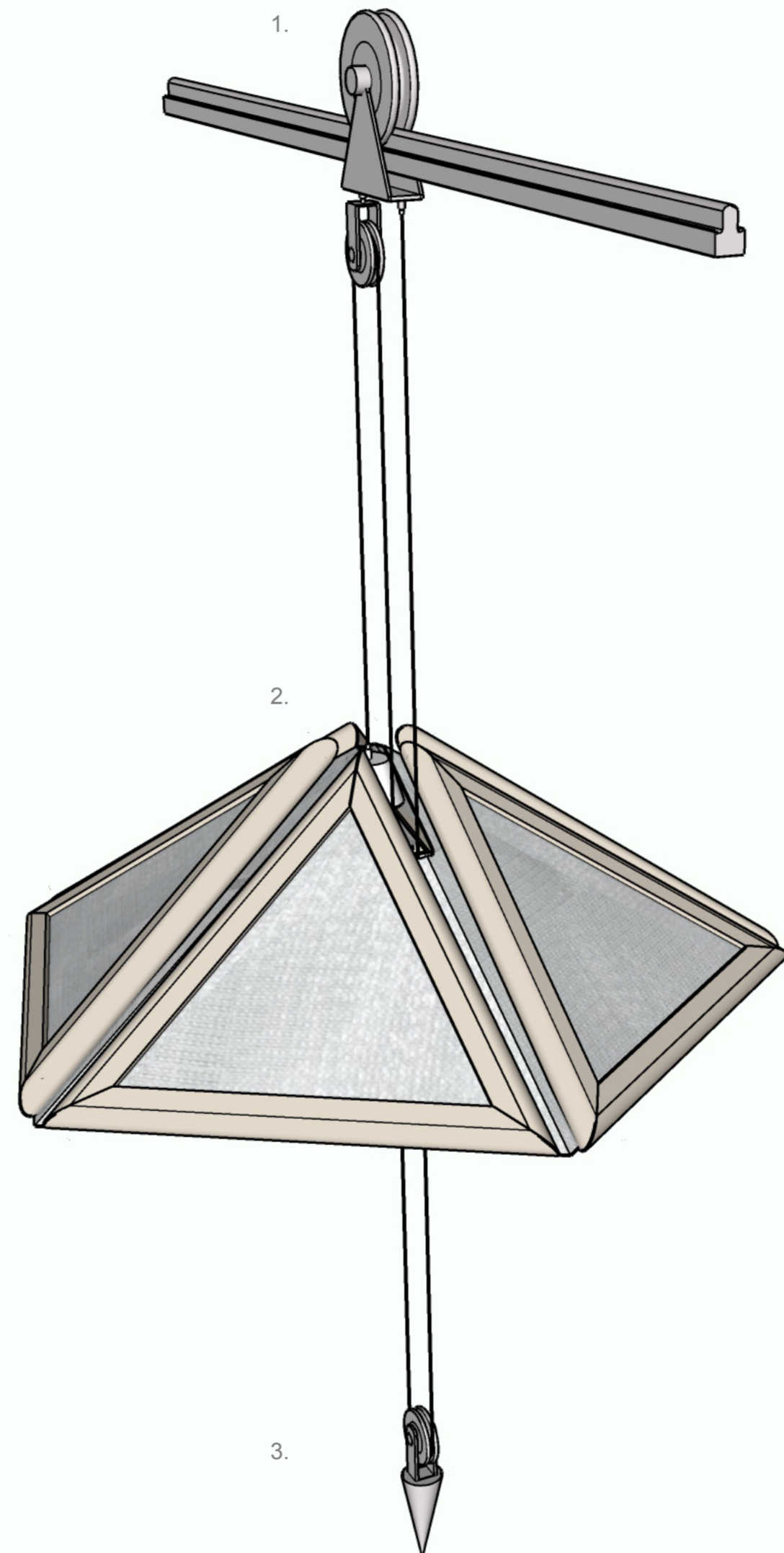

Detail 1.

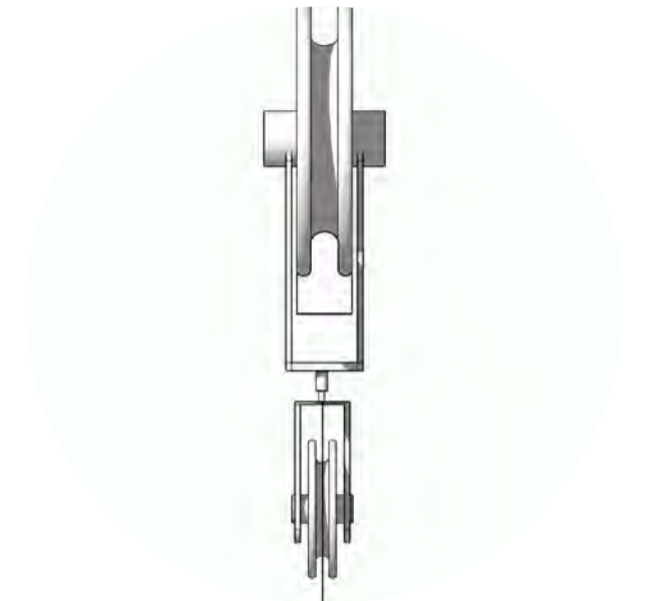

Detail 2.



Detail 3.

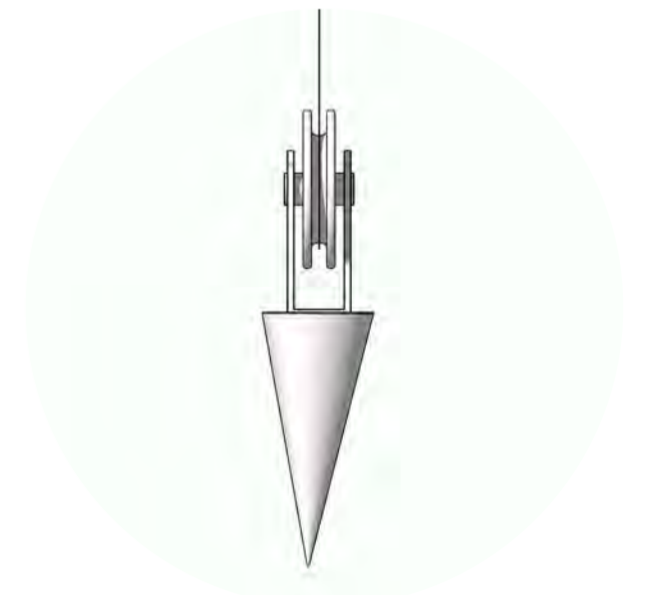

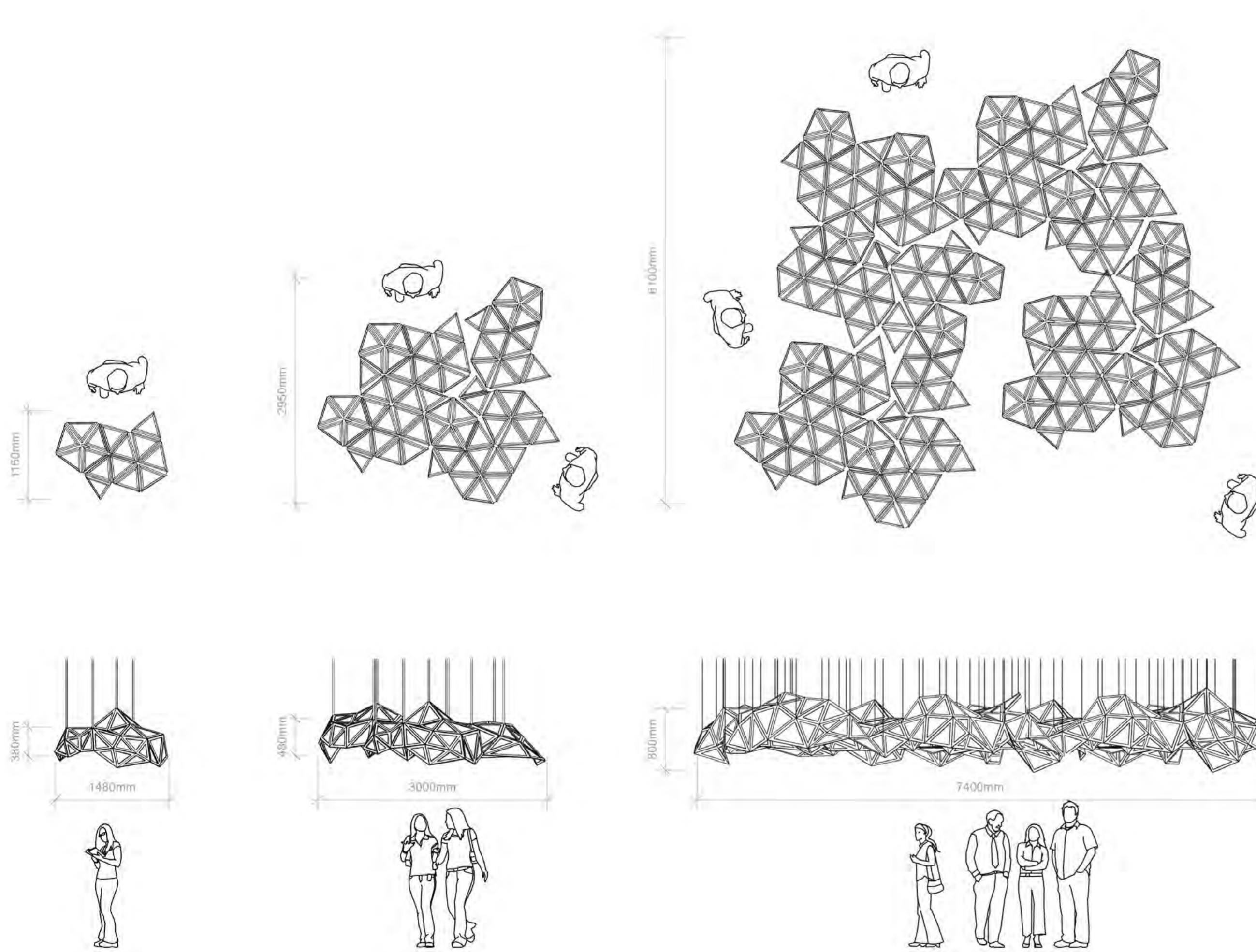

Plans and sections 1:20

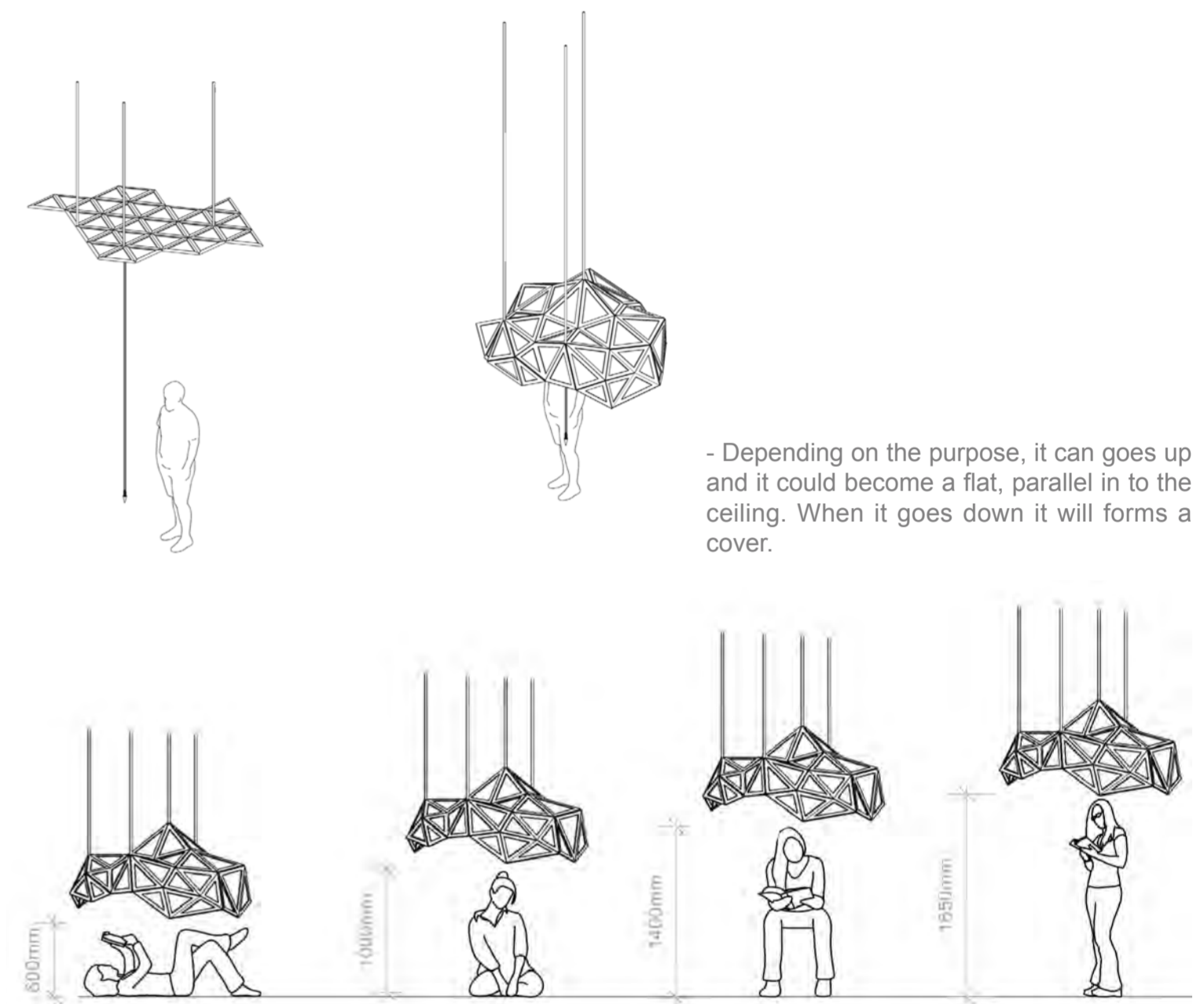

- Depending on the purpose, it can go up and it could become a flat, parallel in to the ceiling. When it goes down it will form a cover.

- Depending on the user's posture, canopy can rise and fall to different heights to isolate noise and create a relatively personal workspace.

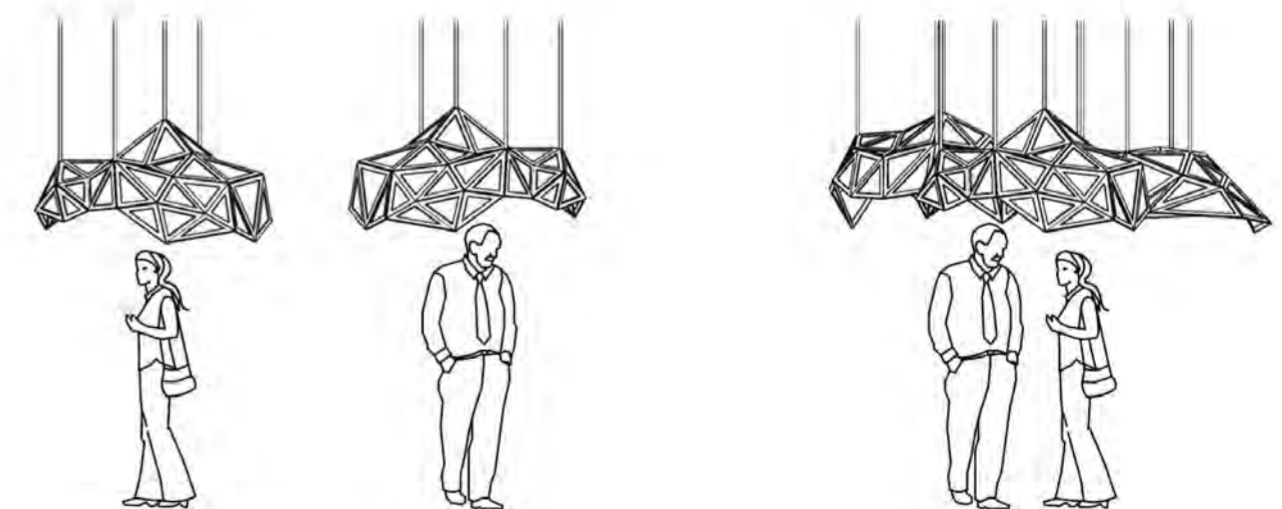

- Depending on the number of users, multiple canopies can be combined. Each canopy edge has a built-in magnet that sucks them together when the user pulls two or more canopies together, creating co-working space.

ORANGE BOX PROJECT : INDIVIDUAL WORK

Secondary Precedent Research : Modular Design

Folding House

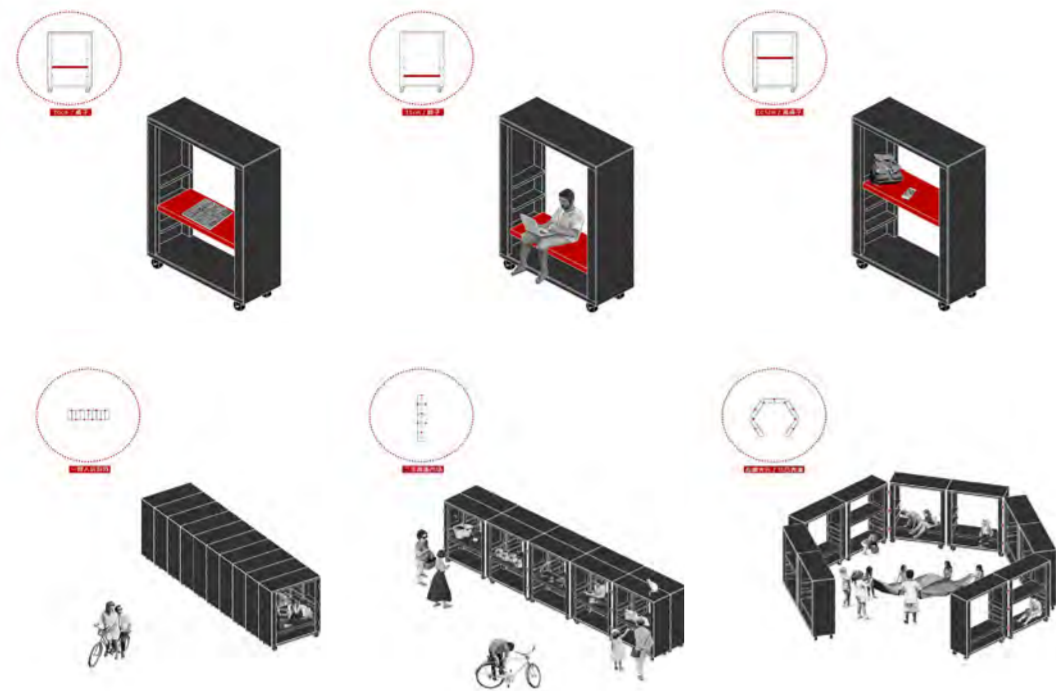

"Folding House" is a box with an area of 9 square meters, which can be divided into 10 separate units and assembled as a flexible micro-center for community activities to best suit different needs and scenarios. It redefines the relationship between people, people and things by changing the spacing between units.

Tetris Table People's Industrial Design Office



This table can be broken apart, rearranged and slotted back together, to allow office employees more flexibility in the way they work. Each part can be used as an individual desk or clustered to form one large conference table. Two or three pieces can also be attached to accommodate smaller work groups. Small openings that are created on the table's surface at contact points offer a place to hold laptop wires.

Cote Ouest



The new offices of the Cote Ouest events agency are located in the former garage of the Bordeaux newspaper Sud Ouest. They are organized in several sub-spaces that we have linked by a large mesh generating various uses. This square mesh in wooden cleats integrates storage, displays, decoration, plants and retractable workstations for occasional uses.

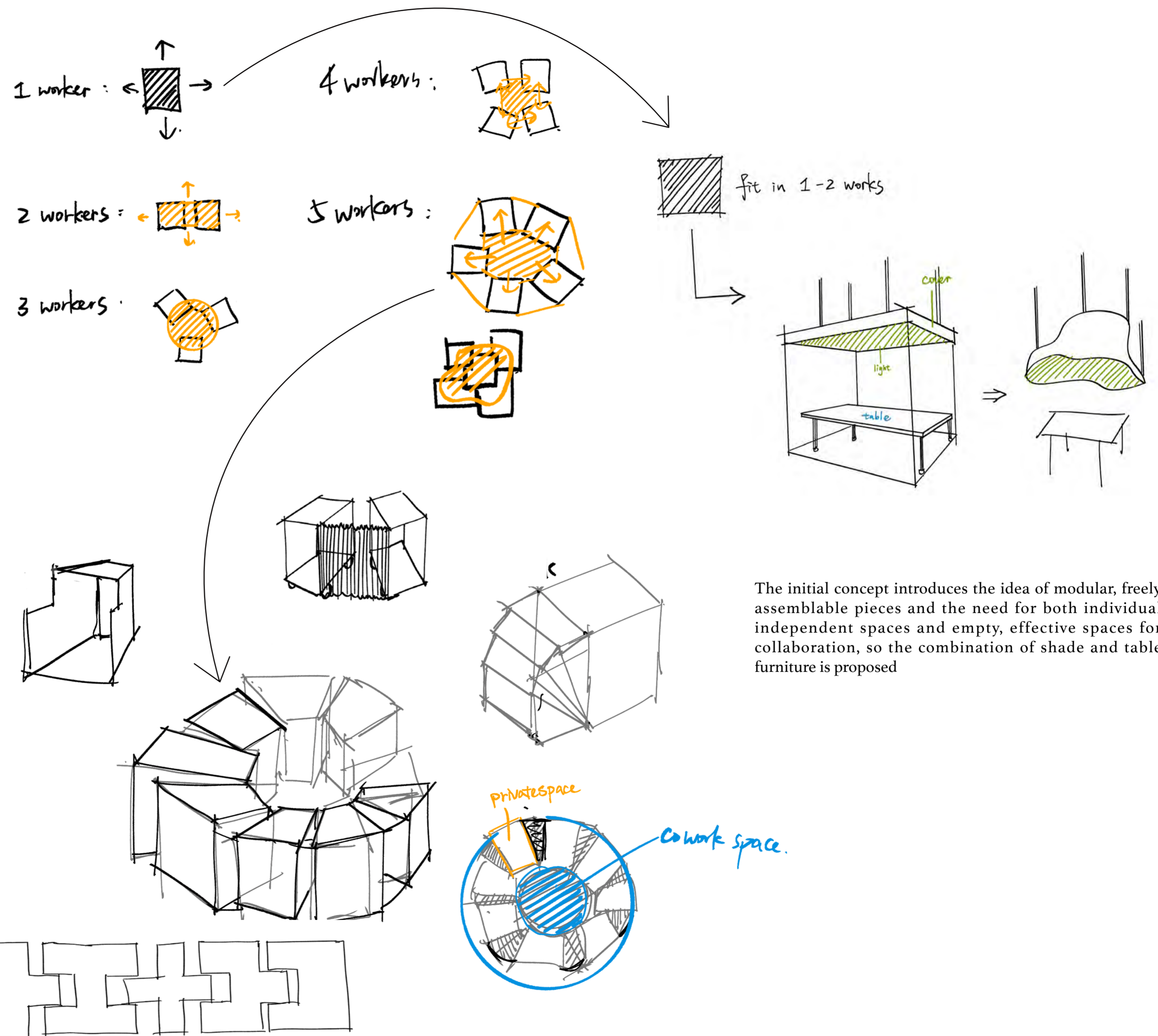

The initial concept introduces the idea of modular, freely assemblable pieces and the need for both individual independent spaces and empty, effective spaces for collaboration, so the combination of shade and table furniture is proposed

COVER



Nacho Carbonell's Cocoon Seats

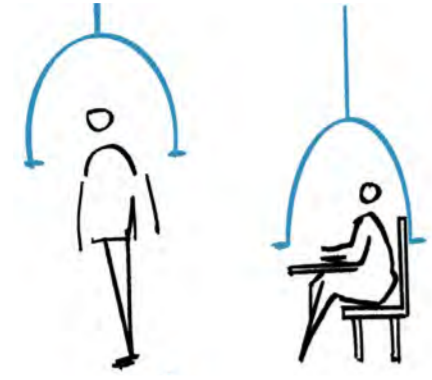

Hearbeat, Charles petillon. London

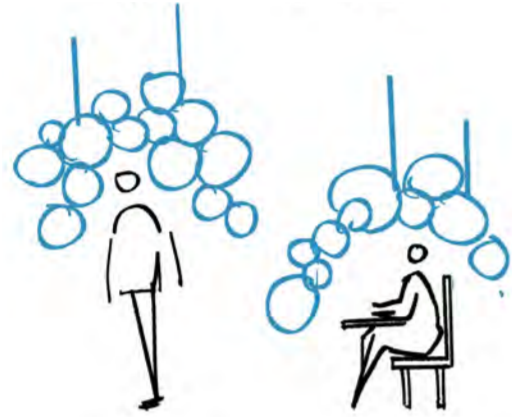

Bloomberg Pavilion, Museum of Contemporary Art Tokyo, Japan by Akihisa Hirata



FURNITURE

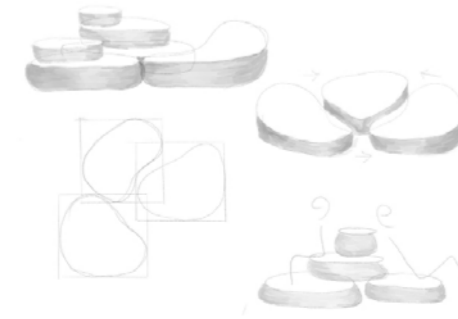
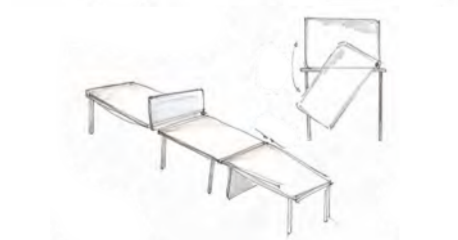
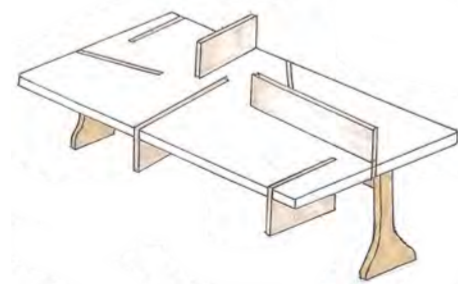
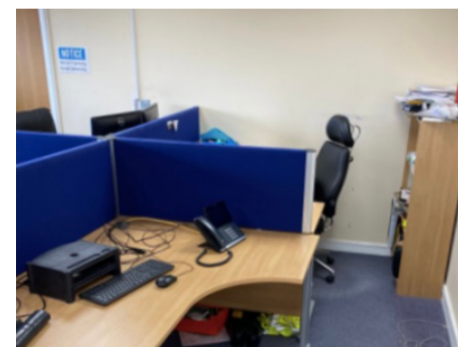

FURNITURE

Absorptive Material
projection wall paint

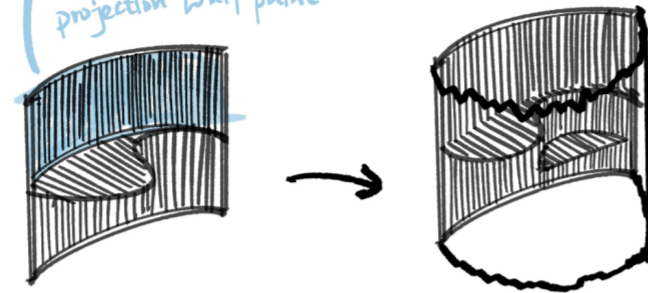

Movable, Changeable furniture
Function: for office needs



COVER

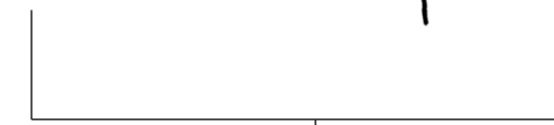
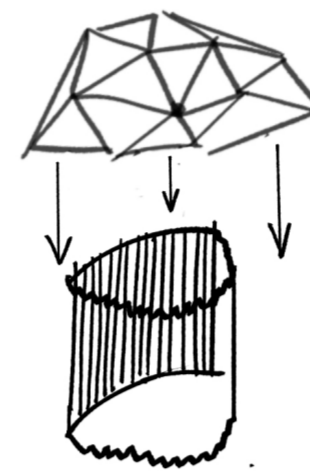

Movable, Detachable and Combinable cover
Function: for privacy, lighting and ambience changes

private

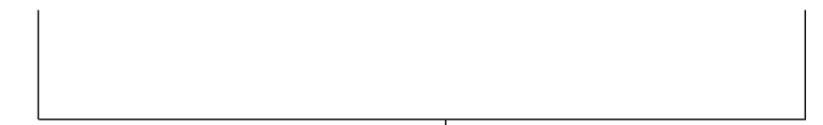
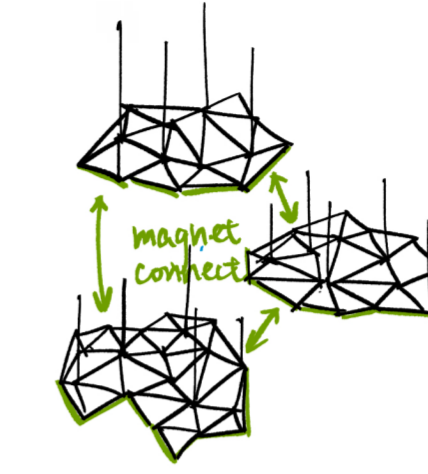

Each individual cover can be magnetised into a larger cover

changing light
↓
ambience
work
leisure

co-working



Form 1
For 1-2 workers standing talking



Form 2
For 1 workers private space

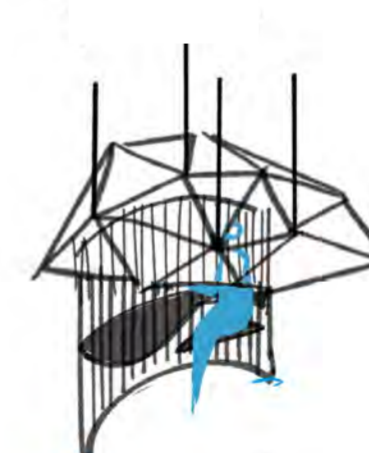

Form 3
1+2+1+2+1+2=co-working space

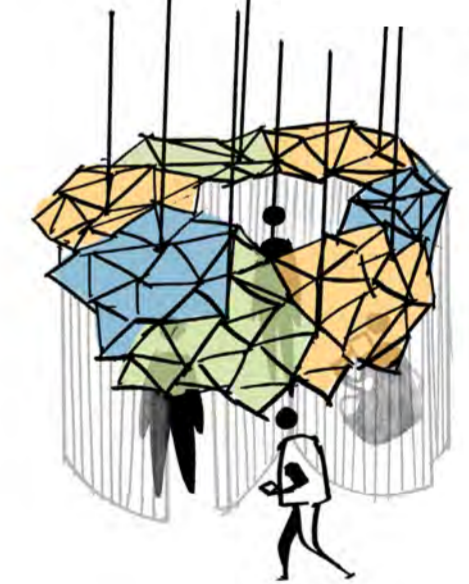

CONCEPT DEVELOPMENT : FURNITURE



Hyperlane Linear Sky Park
ASPECT Studios

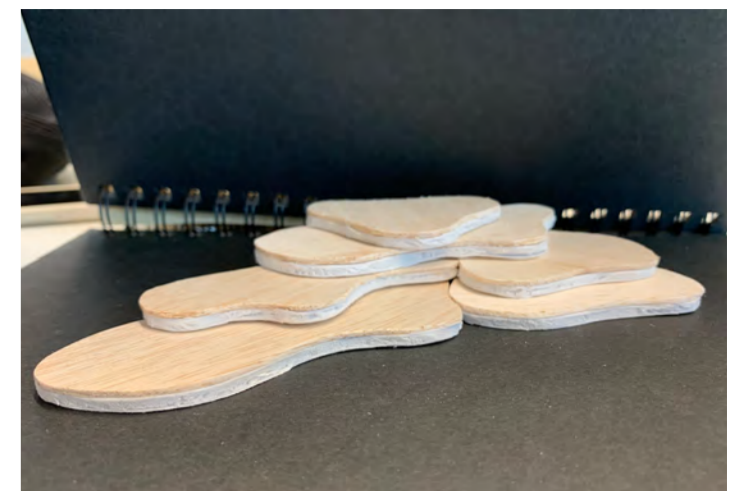
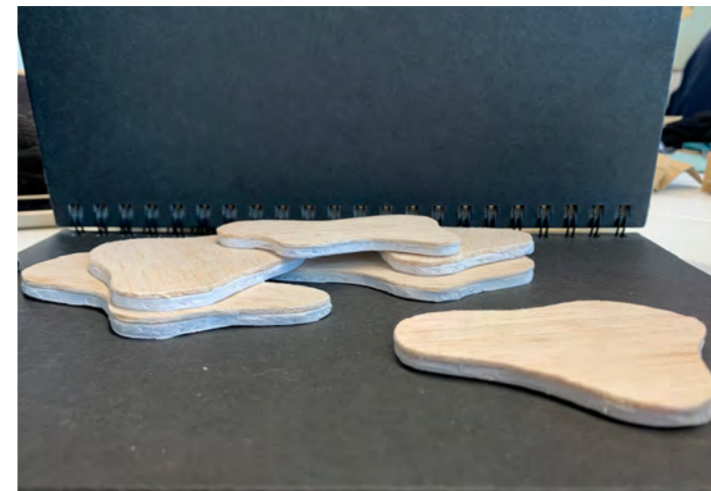
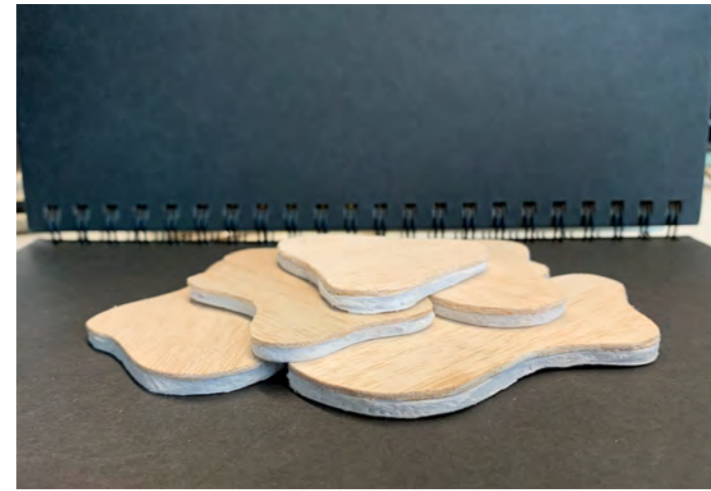

Untitled Benches, Patios, Planters in Arrangement
Michael Clyde Johnson

