

# THE FRONT ROW

181.CRAFT.C24\_02

Located at the previous Tetley brewery site is the Salem church which is a grade 2 listed building. The original congregation of the church was from the demolished white chapel.

The Front Row is a community theatre allowing set design, costume design and theatre performance to happen all in the same building. This follows all of the different aspects of performance that takes place in the space.

This project uses different types of drawing, digital 3D modelling and hand modelling to show the different aspects that go into the community theatre. Including using bright colours to bring the sense of parade and build up to the final event.

The arcade that runs through the building is a public thoroughfare which gives glimpses into the different stage of the theatre production to the public. This space becomes more of a parade on the day of the production.

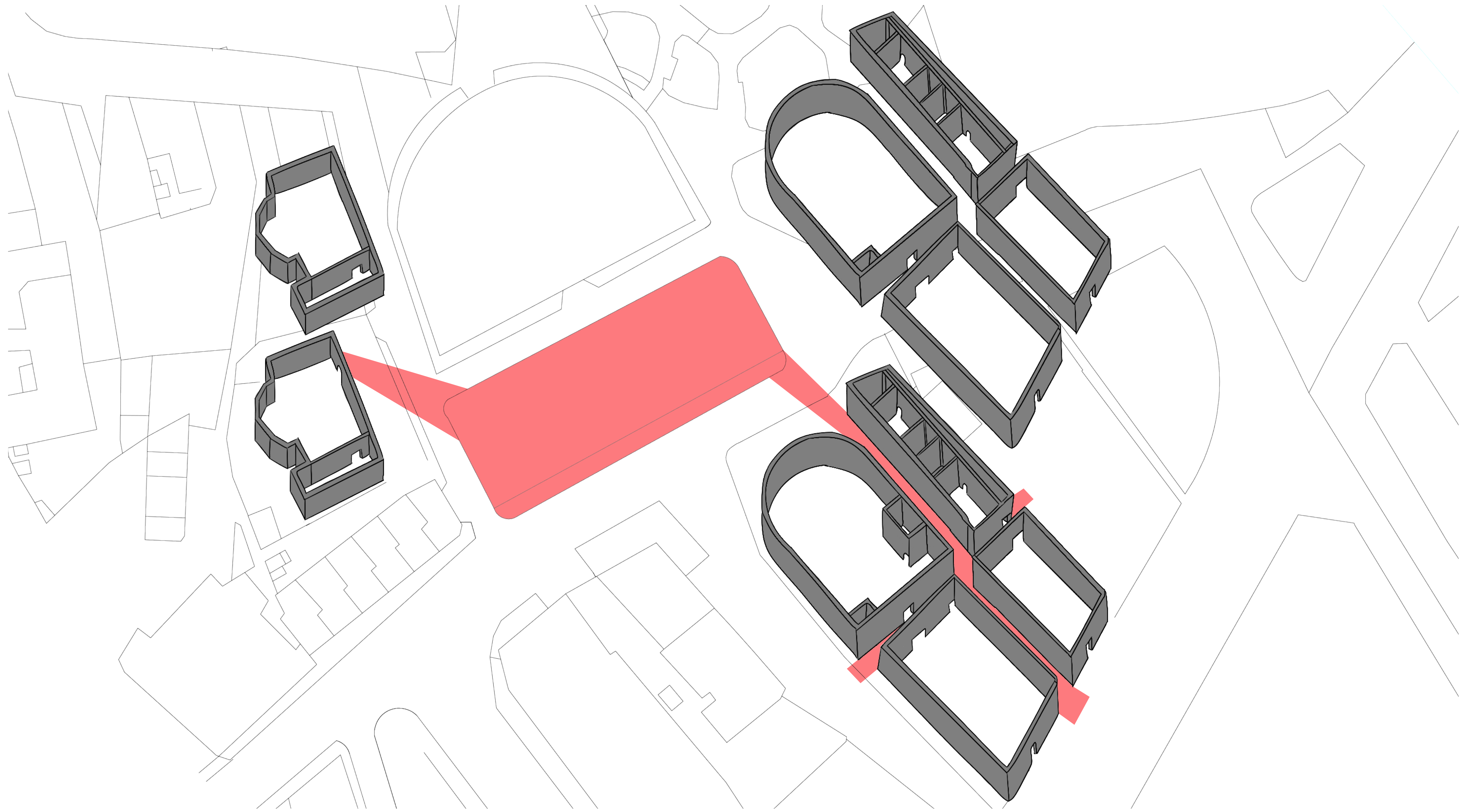



# THE SITE

The site is made up of three parts, an existing building, demolished building and an outdoor space. The Salem church is the existing building which was built in 1791 the curved facade of the building was added in 1906 it is currently a grade 2 listed building and AQL date centre.

The White chapel was built in 1755 and demolished in 1960 after a fire in 1920. The white chapel's congregation moved to the Salem church when it was built and the white chapel then got turned into a primary school until it was demolished.

The outdoor space is a section of land that terrace houses were built on and demolished. This bit of land joins the White chapel and the Salem church. The three of these different elements form the urban fragment of the project.

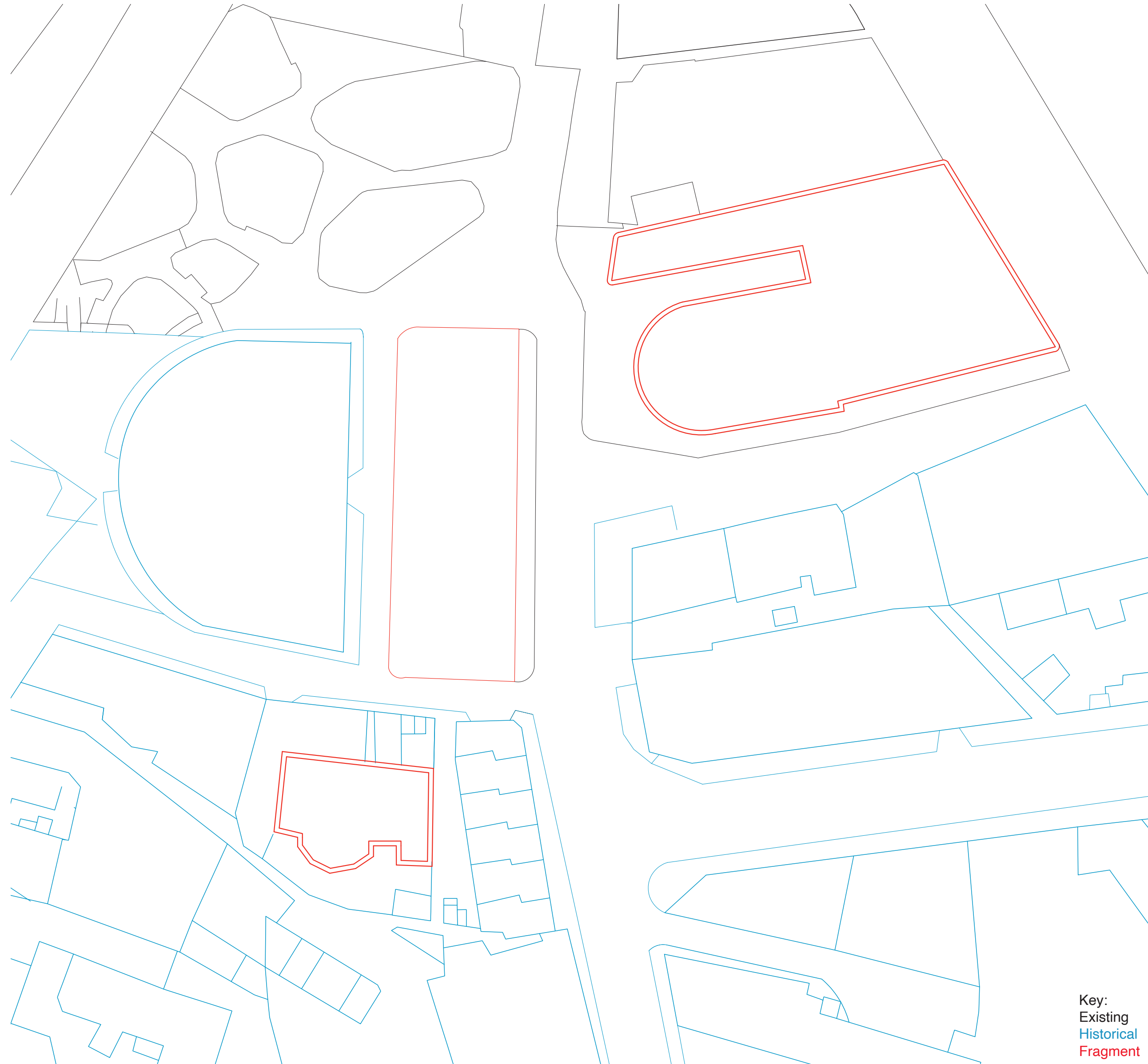

Key:  
Existing  
Historical  
Fragment

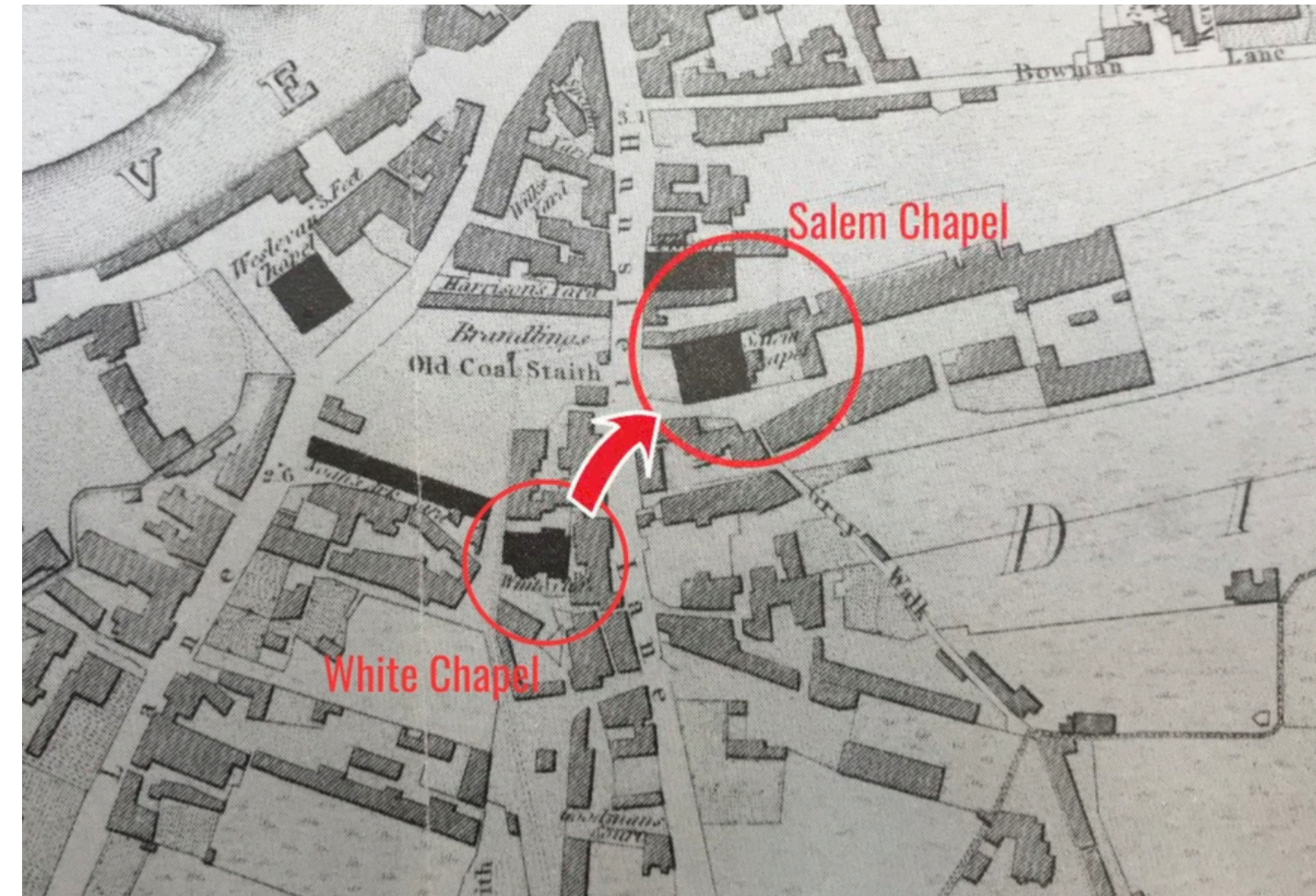



# THE PROGRAMME

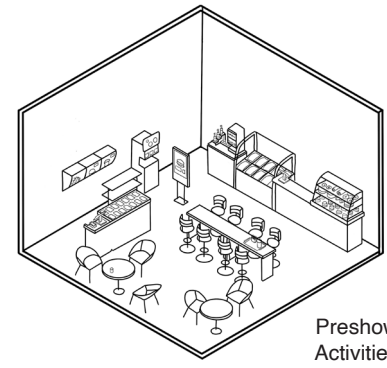
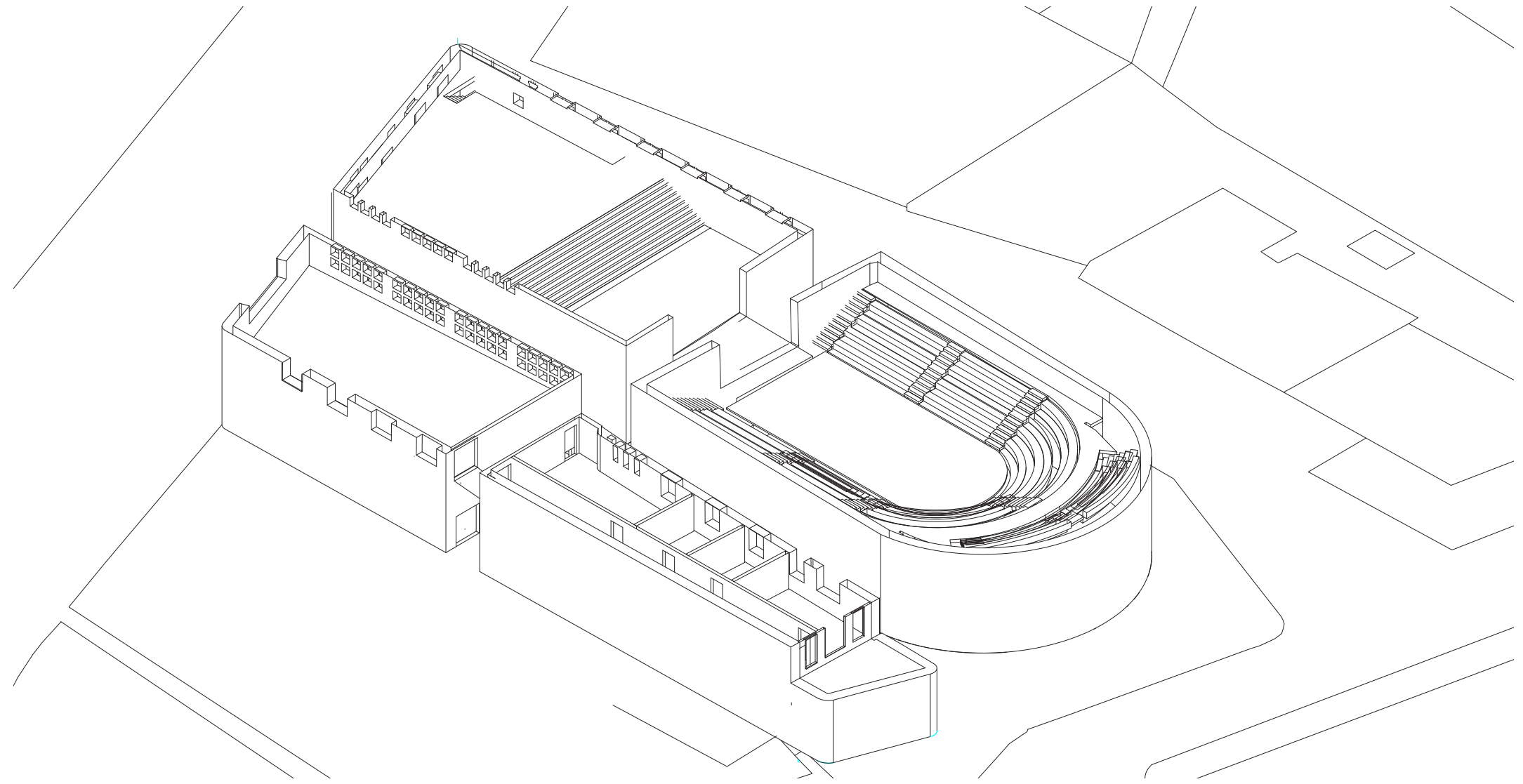
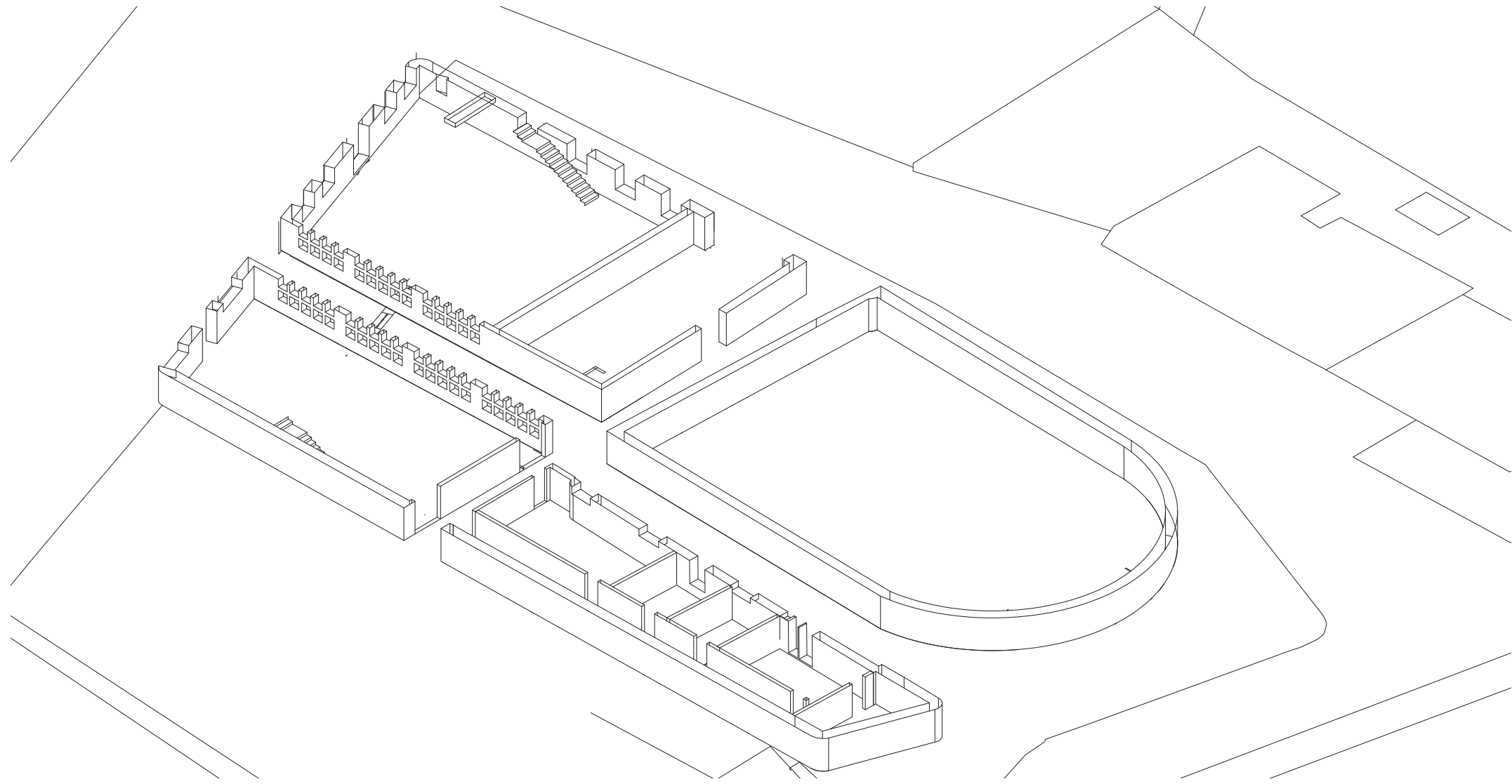

Preshow Activities

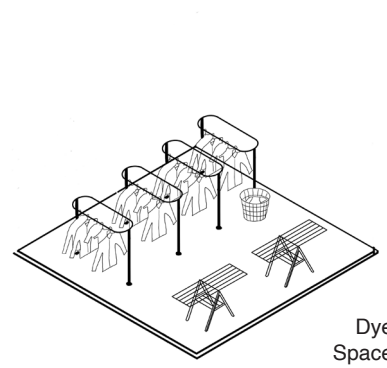

Dye Space

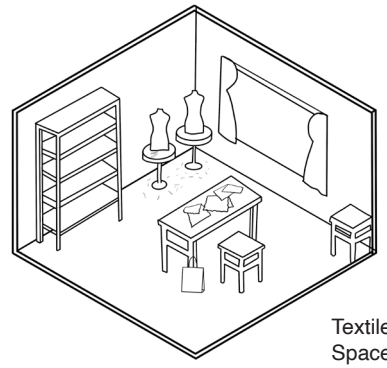

Textile Space

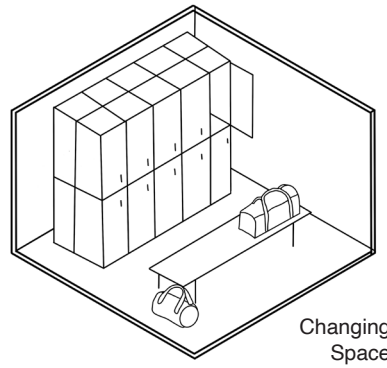

Changing Space

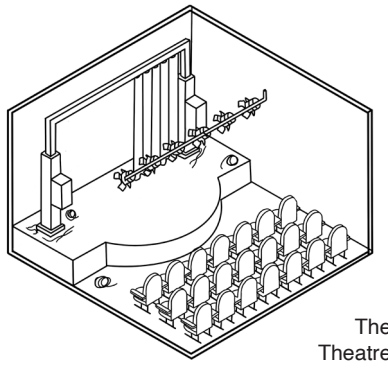

The Theatre

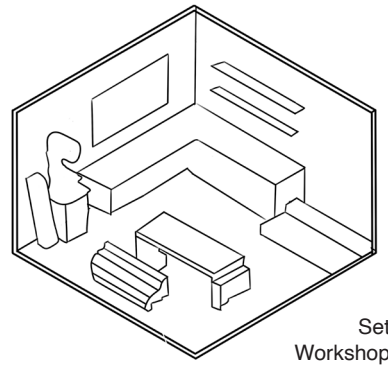

Set Workshop

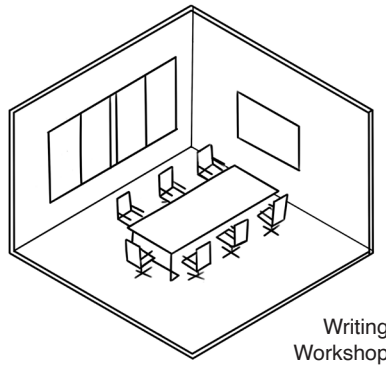

Writing Workshop

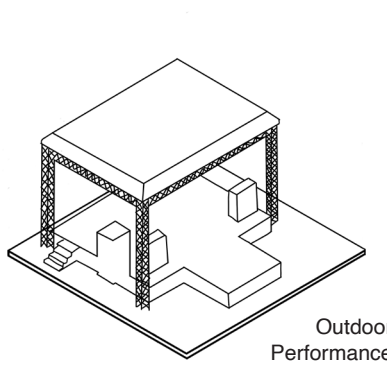

Outdoor Performance

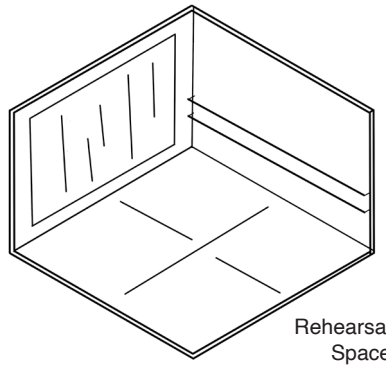

Rehearsal Space

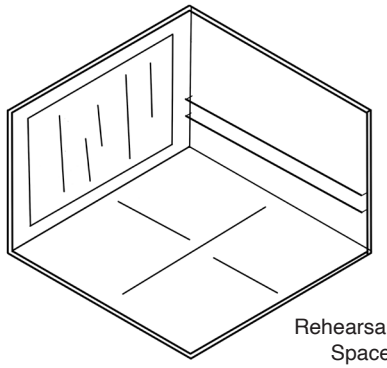

Rehearsal Space

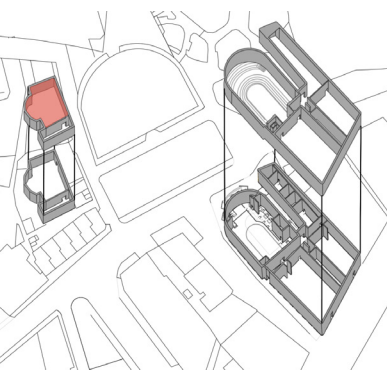
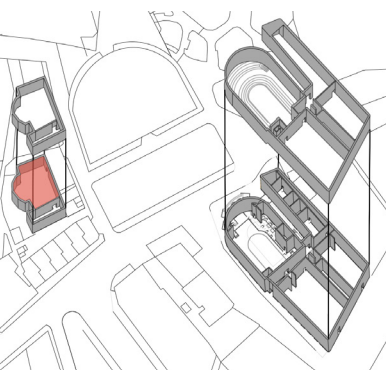
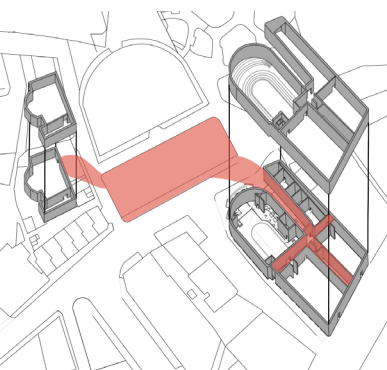
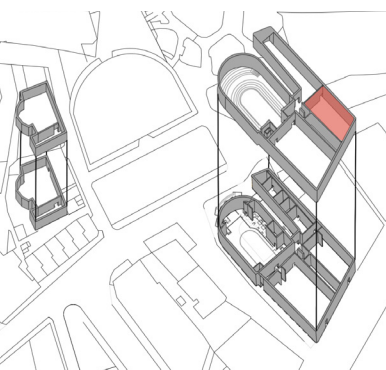
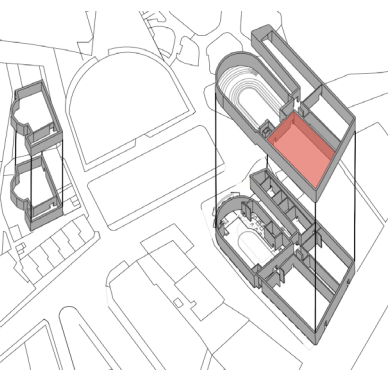
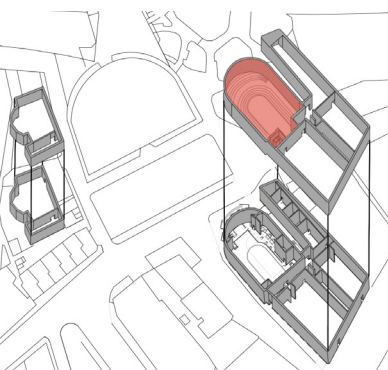
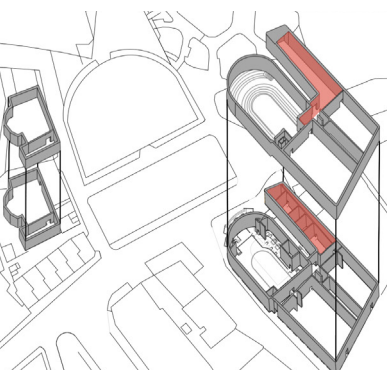
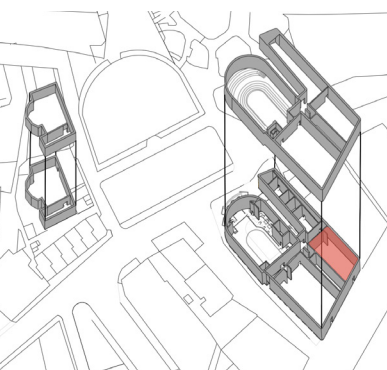
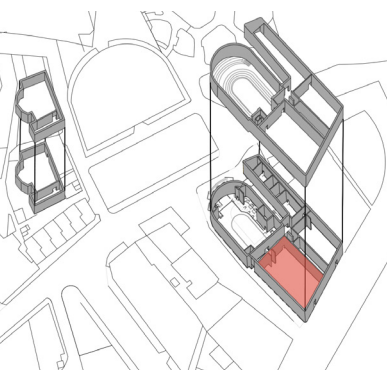
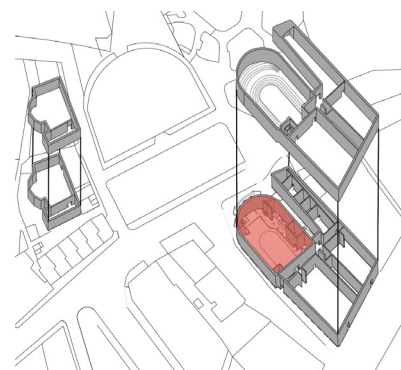
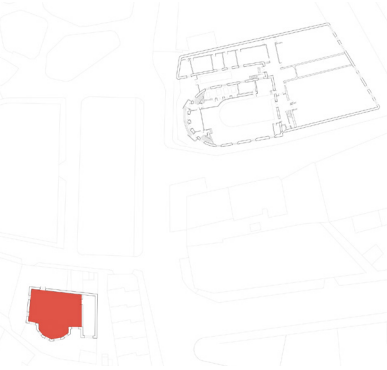
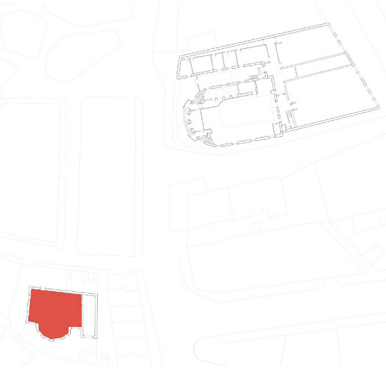
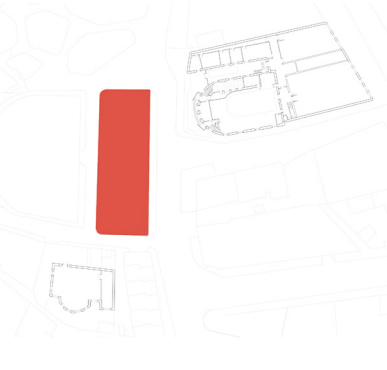
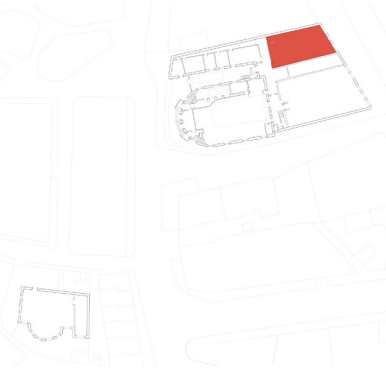
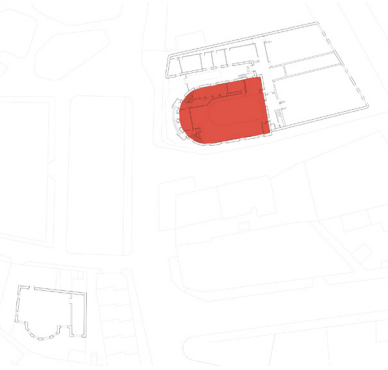
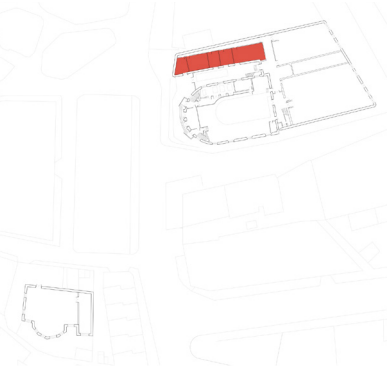
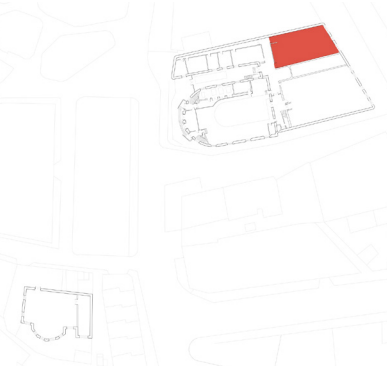
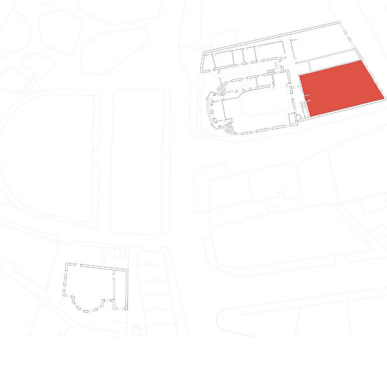
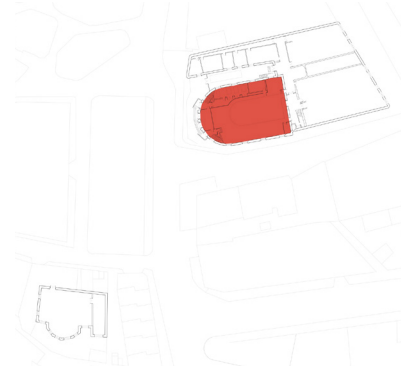



# THE PROPOSAL

## Spaces

- 1: Textile workshop
- 2: Dye workshop
- 3: Materials delivery and storage area
- 4: Pre-show activities
- 5: Amenities
- 6: Theatre

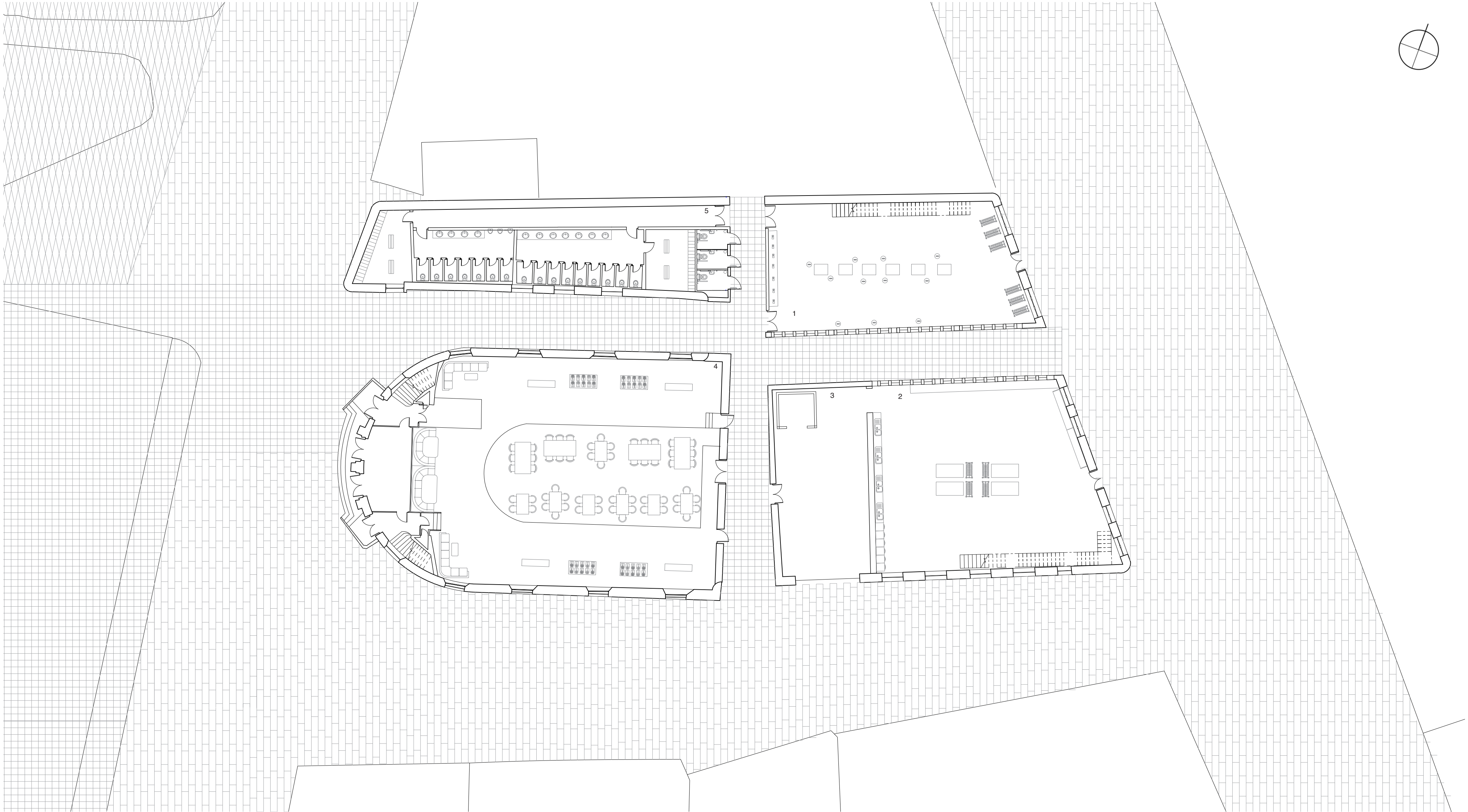



# THE ARCADE

