

The role of art in the expression of authenticity

In 2084, the world is overrun by the use of AI. This creates a need for escape and a way of finding what is truly authentic. Through the use of the ruins of an Abbey, a space is formed to sketch, paint and sculpt and to use physical skills to feel free and teach others about the arts. The site and the desire for creation allows this break away from the world as it is, to use art as a way of grounding. As the project develops, a hand-drawn style begins to dominate its representation, reflecting the project's ethos within the 2084 world.

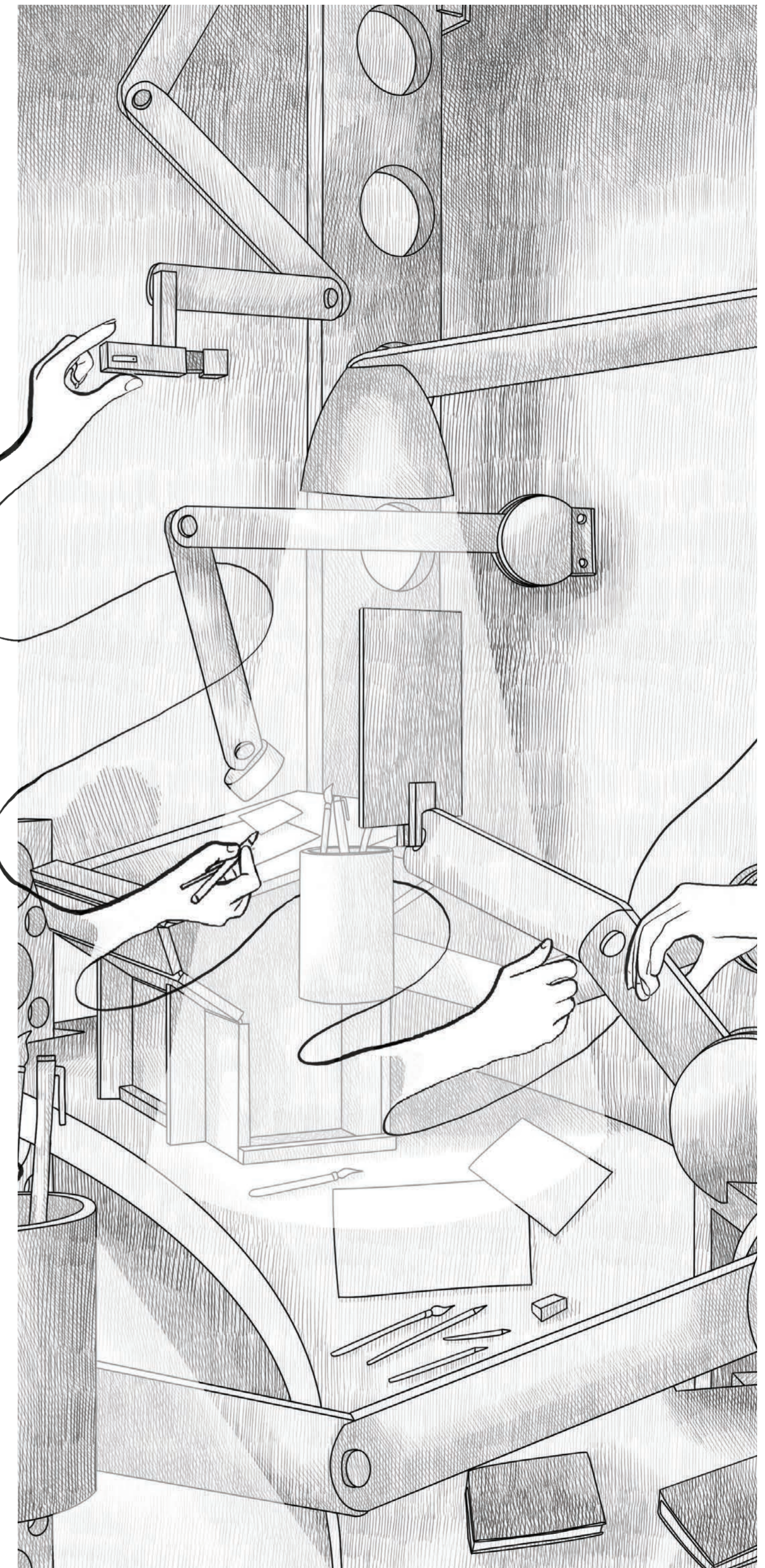

The Art Studio

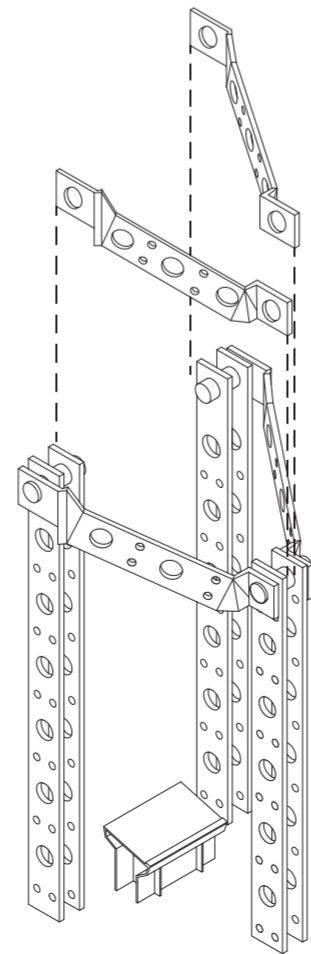
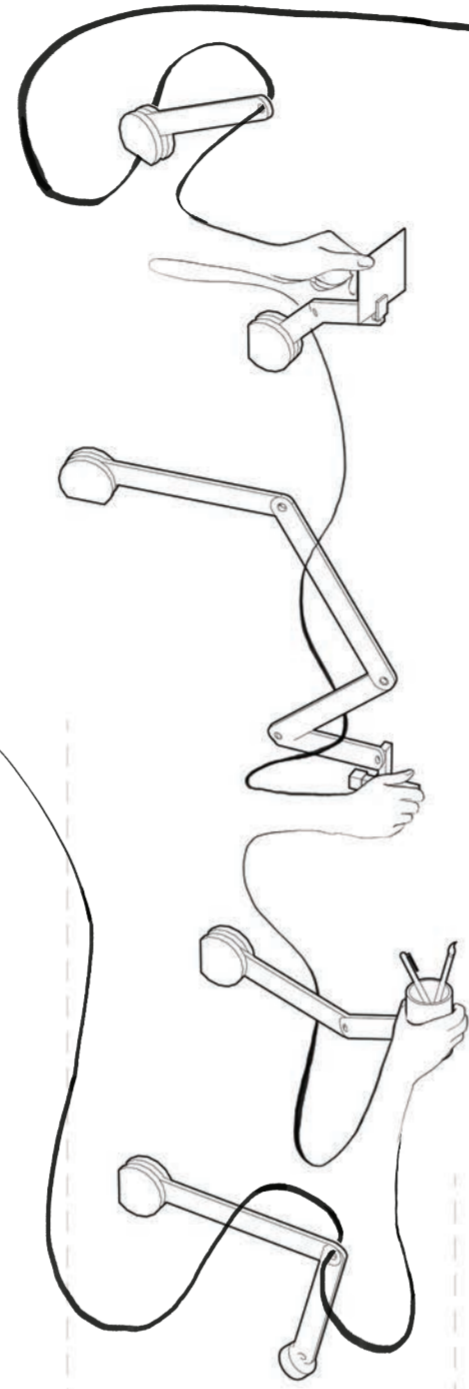
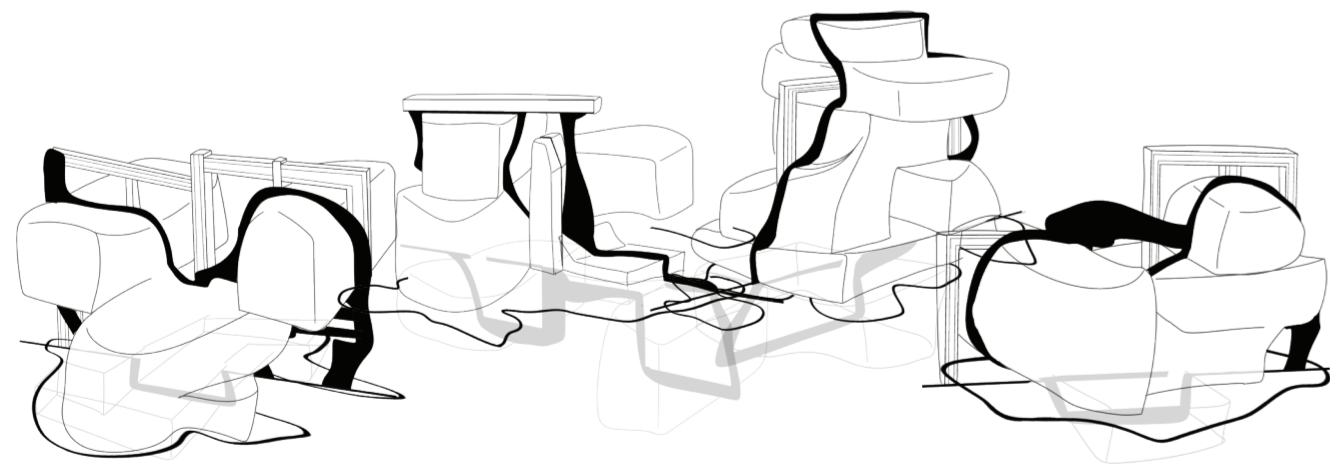
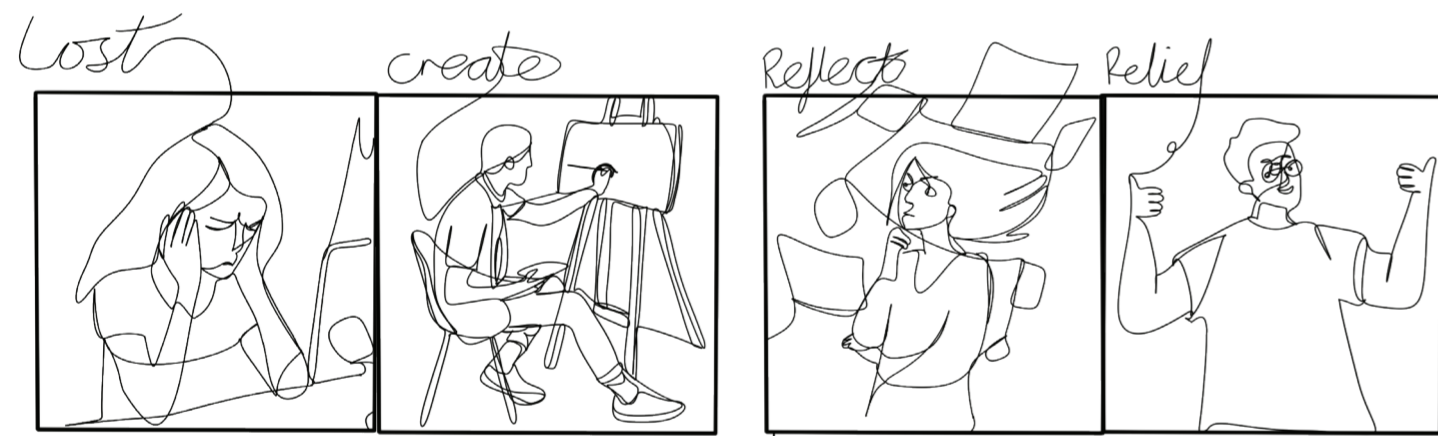
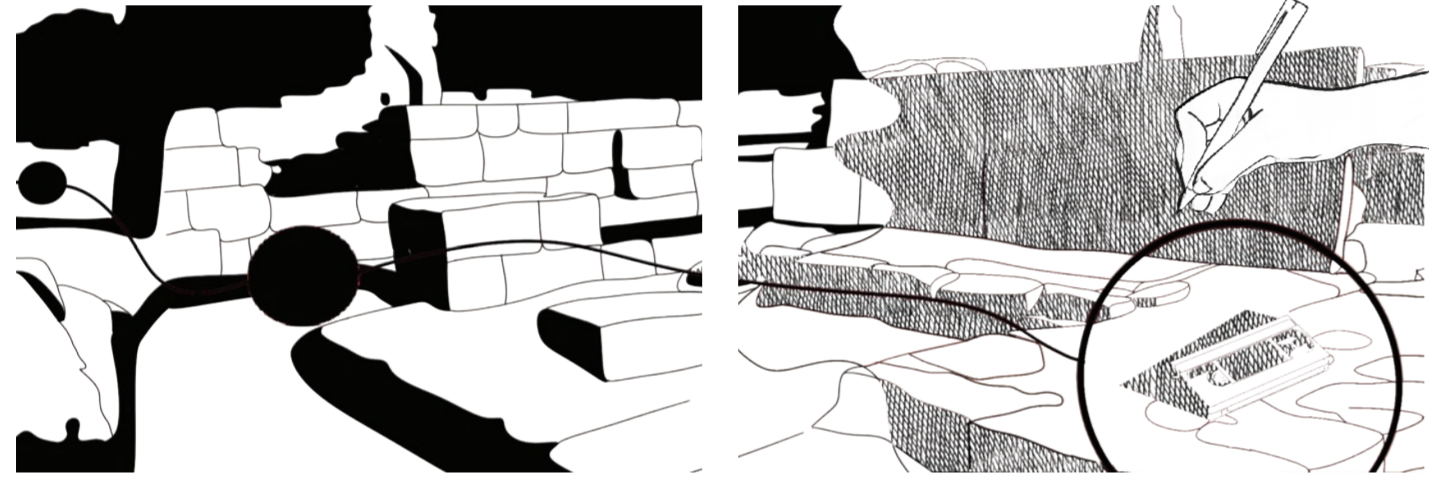
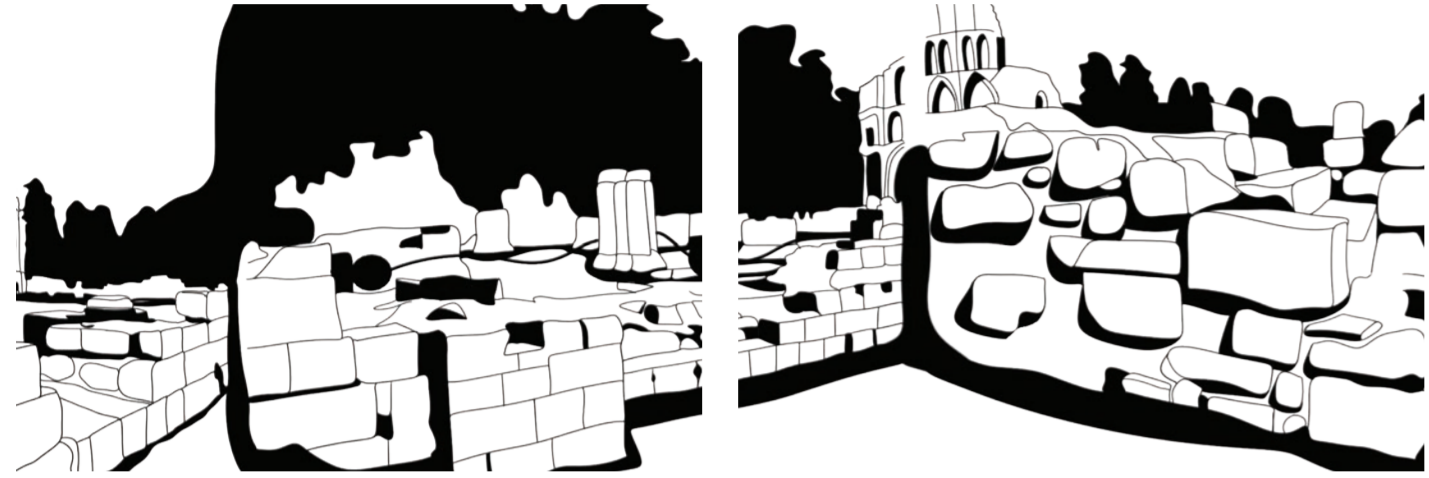