

Eggshells waste with insect space

From Waste to Ecological Circularity: Learning Through Sustainable Design

This project transforms discarded eggshells into a biomaterial, applying principles of circular design to create a space for insects.

Through modular tile-making, each individual product accumulates into a collective micro-habitat, revealing the interdependence between species, materials, and environmental systems.

By turning everyday waste into tangible environmental action, the project puts sustainable design into practice and contributes to a broader ecological cycle.



The Site: Tolworth Court Farm Fields

Tolworth Court Farm Fields (in South-West London) is a large nature reserve spanning across 100+ acres of land. Our tile design has been curated within the site.

We have taken in the surrounding environment, animals and insects to ensure the material is safe. Outside the field in Tolworth are multiple restaurants and cafes that uses eggs. The main source of the material of eggshells can be collected from them.



● elementary school ● eggshell collection



Estimate number of eggs eaten in the UK in 2025 :

14.5 billion eggs total per annum
39.6 million consumed per day
209 annual per capita consumption



*Source: British Egg Industry Council (2025)

Our Aim

- 01 Educational Objective** — Transforming Food Waste into Value
- 02 Experiential Objective** — Creating a Safe and Engaging Workshop
- 03 Ecological Objective** — Creating Micro-Habitats for Insects



* Partially AI-assisted visual

Target user

- Daytime**
 Adults (in the local communities) and children (primary and high school children) make their own individual tile and assemble them on site. Insects (such as butterflies and mosquitos) are attracted to the tile which acts as a bug hotel.
- Nighttime**
 Pipstrelle bats are the common species of bats found in the site- they would come and feast on the insects.
- Seasons throughout the year**
 Spring, summer and autumn would be the ideal time where the workshops would occur as bats would hibernate throughout the winter.

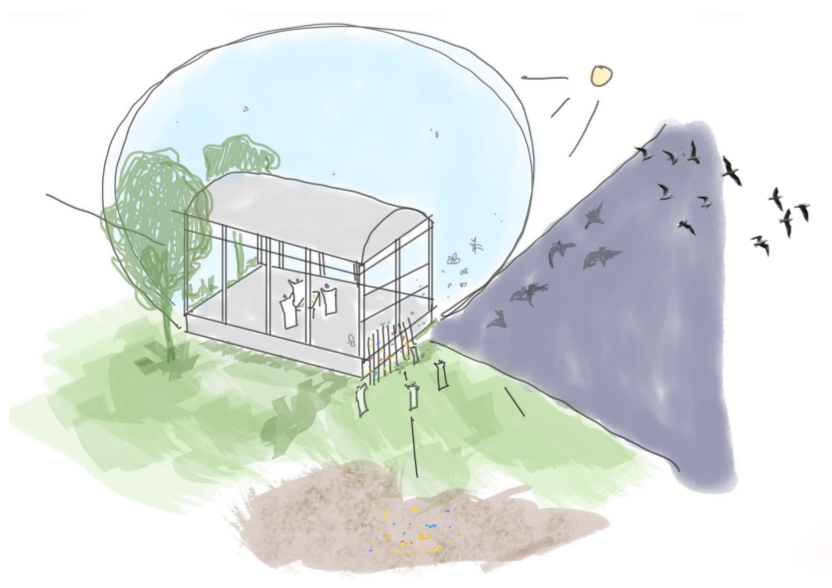

Ingredients and materials



Turmeric
The colour is vivid, but turmeric powder is more likely to act as an "insect-repellent" material.



Experiments

Samples	Ingredients and online research	Properties				Feedback/ notes	Result
		cracked?	shrinkage?	drying time?	held without breaking?		
	<ul style="list-style-type: none"> - cooked eggshells (hand-crushed) - water - sodium alginate - calcium chloride https://storeprojects.org/wp-content/uploads/2020/08/MakersManual9-EGGSHELLCERAMICS.pdf	yes and crumbly	n/a	under a week	no	The eggshells are roughly crushed and too large,	Failed
	<ul style="list-style-type: none"> - cooked eggshells (blended) - water - sodium alginate - calcium chloride https://storeprojects.org/wp-content/uploads/2020/08/MakersManual9-EGGSHELLCERAMICS.pdf	yes due to touching when not completely dried	n/a	under a week	no	Better structure than sample 1 using fine eggshell powder but proportions were not accurate.	Failed
	<ul style="list-style-type: none"> - uncooked eggshells (blended) - water - almond oil - sodium alginate - plain flour Material Commons	partially	1-2mm	days, needs to be heated or use a	yes	Turned out to be oily and soggy so the extra oil needed to be dabbed off.	Failed
	<ul style="list-style-type: none"> - cooked eggshells (blended) - water - sodium alginate https://storeprojects.org/wp-content/uploads/2020/08/MakersManual9-EGGSHELLCERAMICS.pdf	no	4-5mm	heated for a week	yes	Experimented with sodium alginate (biodegradable) Eggshell 25g Water 25 mL Sodium Alginate 2% (2% It should be 0.5g, instead of 1g) Apply vinegar to the Mold surface	Successful
	<ul style="list-style-type: none"> - cooked eggshells (blended) - water - sodium alginate - orange peel - calcium chloride https://www.instructables.com/Exploring-Eggshell-Ceramics/	no	1.5mm	under a week	yes	Experiment With Sodium Alginate (biodegradable) Eggshell 25g Water 25 mL Sodium Alginate 2% (2%, added 1g+ Calcium Chloride 1g orange peel powder 8.7g	Successful
	<ul style="list-style-type: none"> - cooked eggshells (blended) - water - sodium alginate - wood shaving https://www.instructables.com/Exploring-Eggshell-Ceramics/	no	3-4mm	under a week	yes	Eggshell 25g Water 35 mL Sodium Alginate 1g Wood shaving 10 g	Successful
	<ul style="list-style-type: none"> - cooked eggshells (blended) - water - sodium alginate - calcium chloride - dried petals https://www.instructables.com/Exploring-Eggshell-Ceramics/	yes	n/a	under a week	no	Eggshell 25g Water 30 mL Sodium Alginate 1g Calcium chloride 1g Petal 1g	Failed
	<ul style="list-style-type: none"> - cooked eggshells (blended) - water - sodium alginate - vinegar 	n/a	n/a	n/a	no	Vinegar 10 ml Eggshell 15 grams Water 200 ml Sodium Alginate 4 grams	Failed

Successful Failed

Inspired by the form of a bat

Form exploration

Through vacuum forming tests, sharp angles were refined and draft angles increased to improve forming quality and mould release.

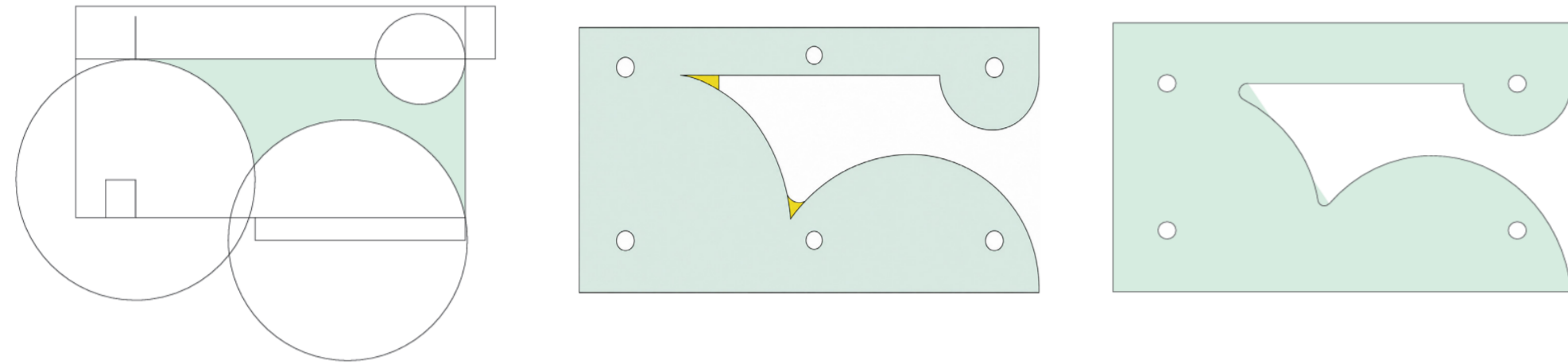

Tile Model Making



Design development

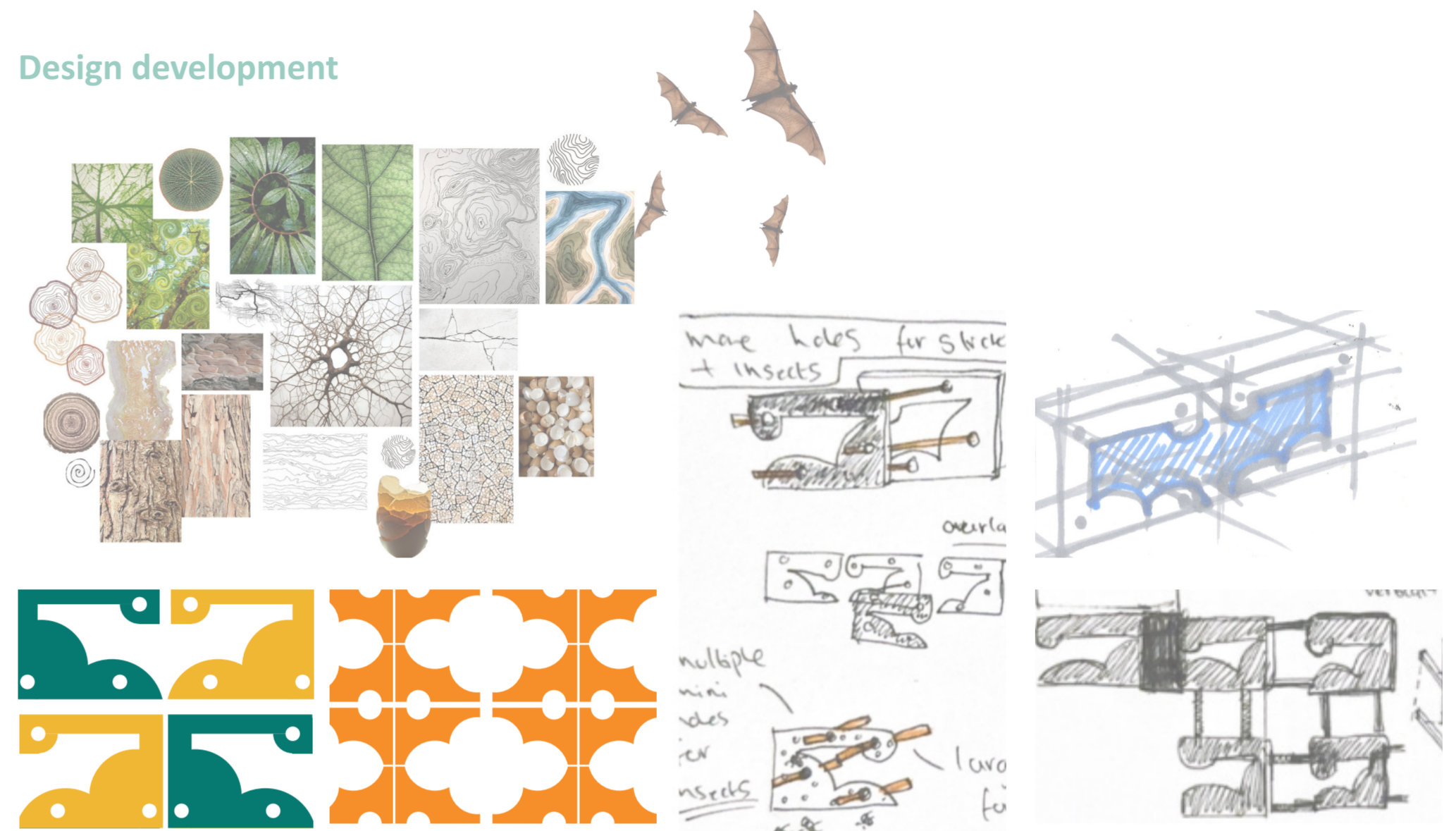

layering test

Visual exploration of how the tile arrangement and negative space create bat-like forms and a sense of movement as the sunlight changes direction throughout the day.

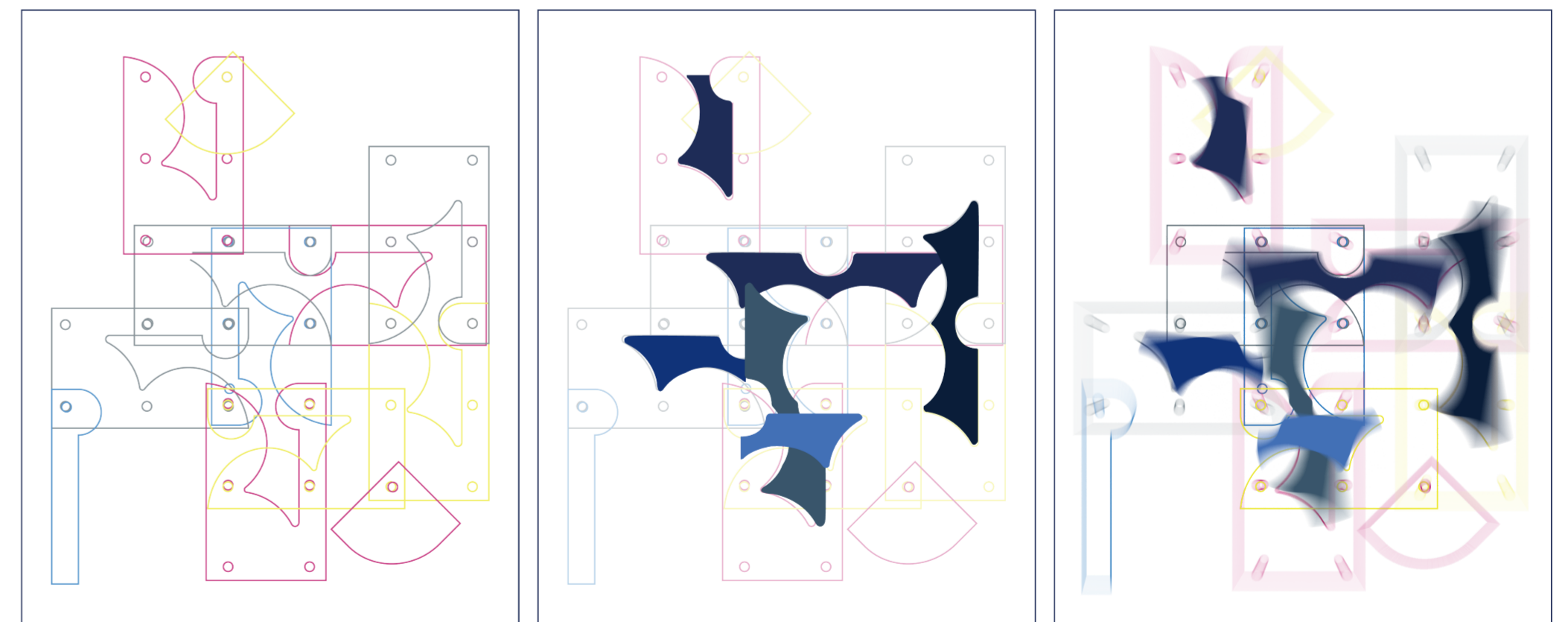

Elevation

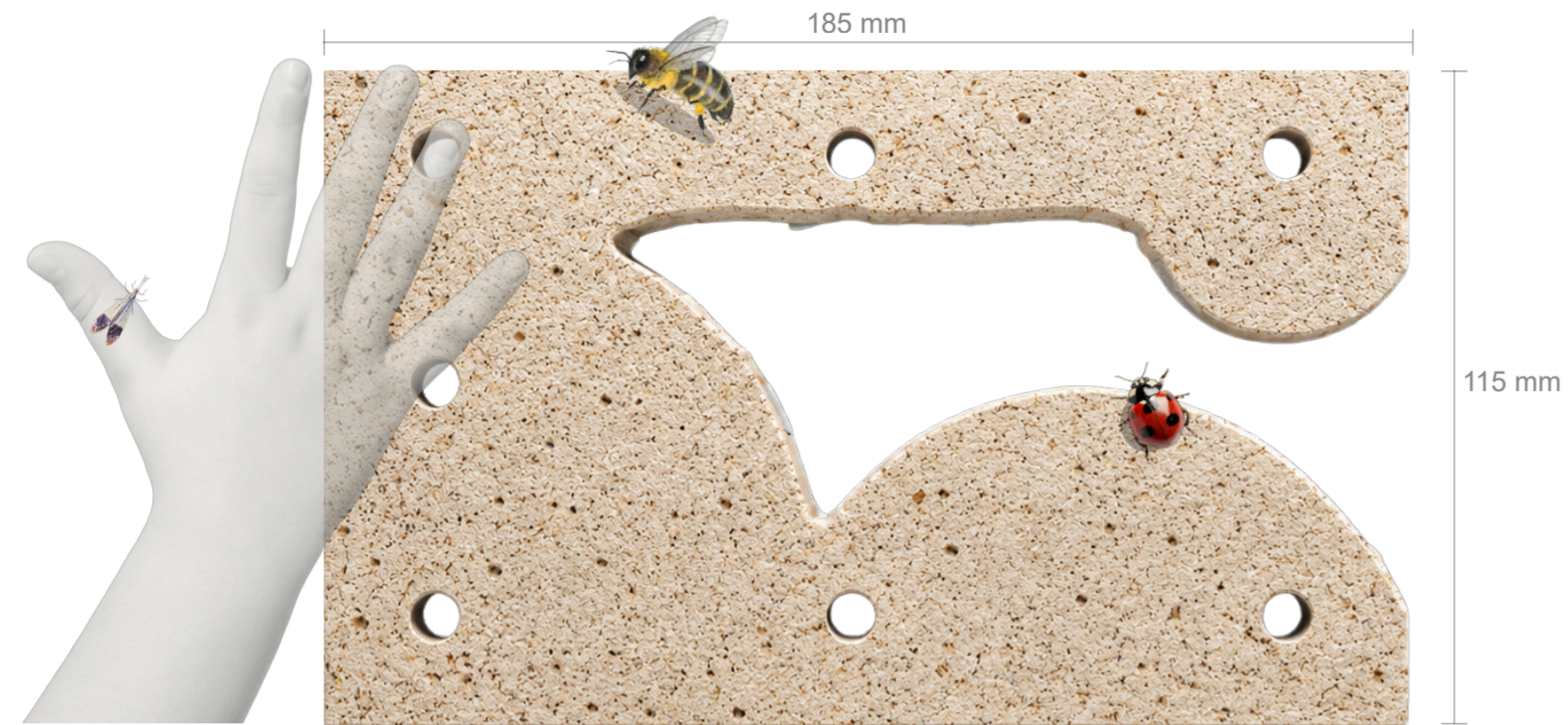

Front elevation

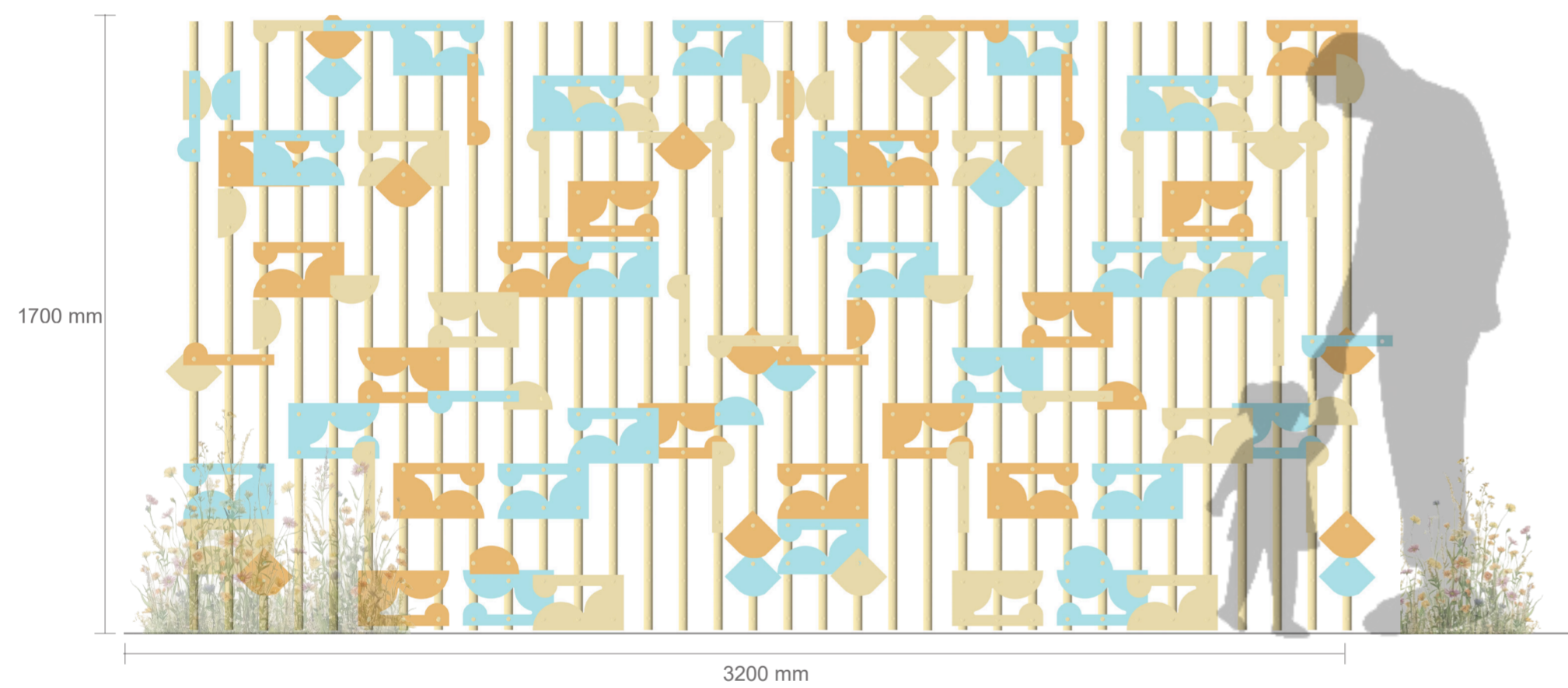

Construction detail

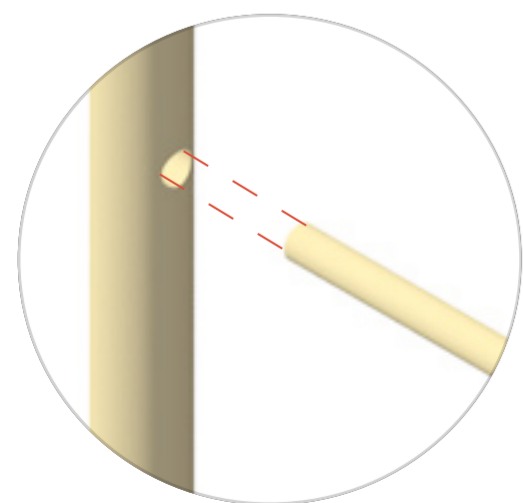

Horizontal pole into vertical rod

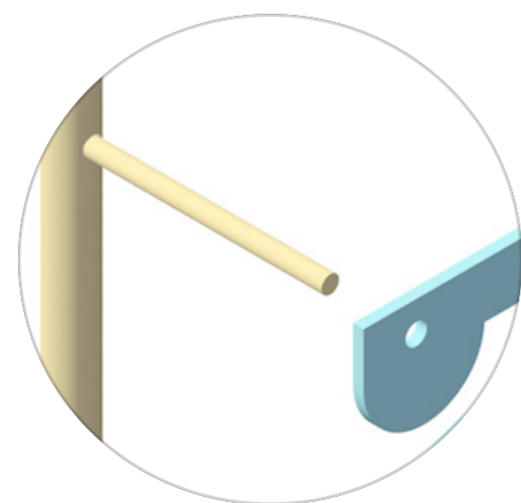

Tile onto Horizontal pole

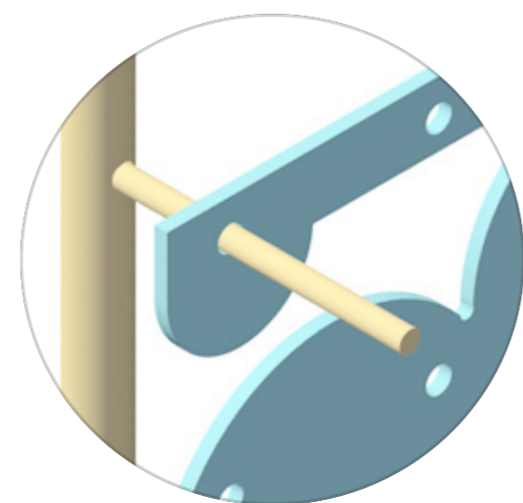

Tile assembled onto Horizontal pole

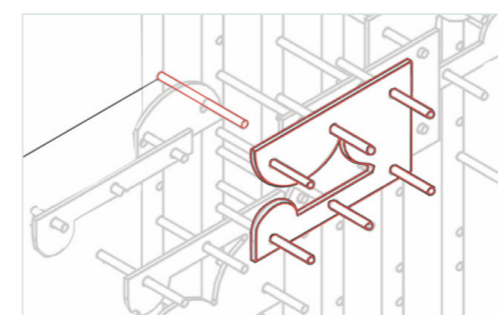

Tile Installation

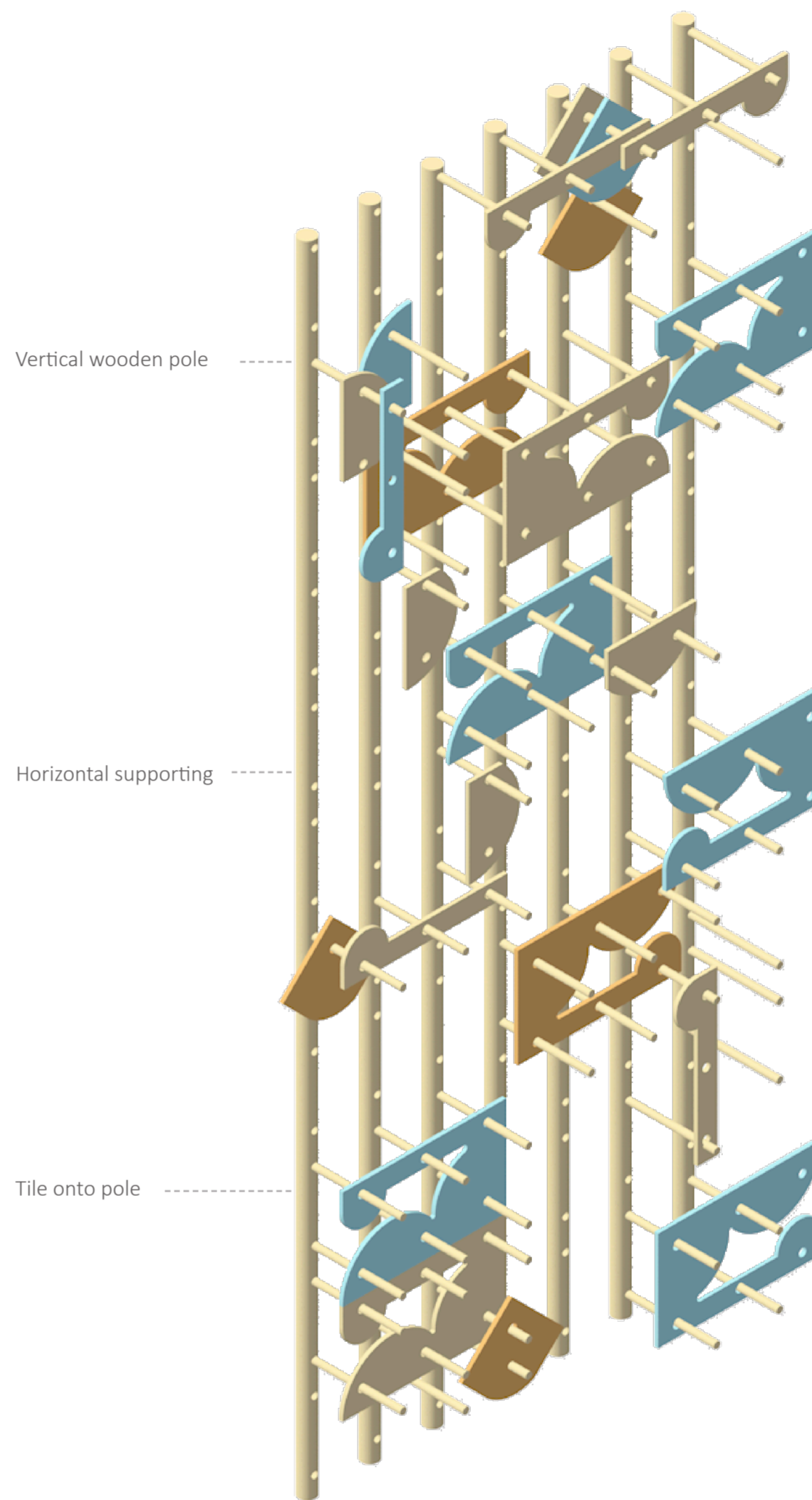
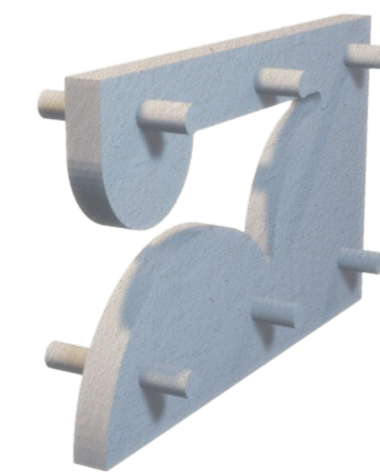

Assembly process

1

Vertical rods with holes drilled into them ready for horizontal wooden rods to be placed

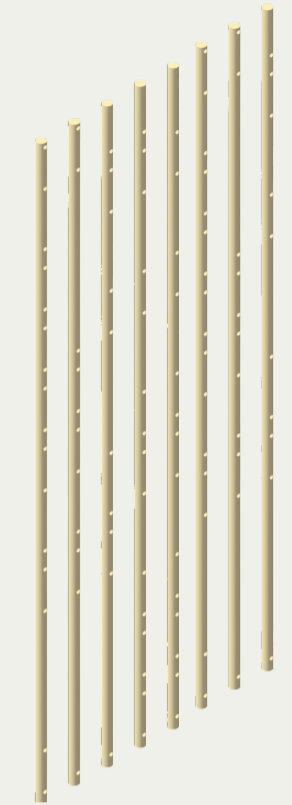

2

Horizontal poles are placed into the holes tightly

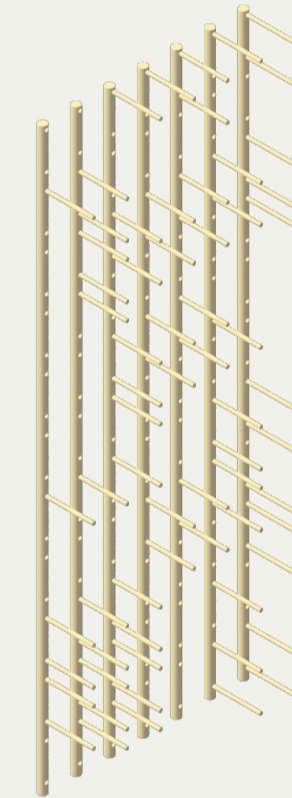

3

The tiles are arranged on the horizontal wooden poles

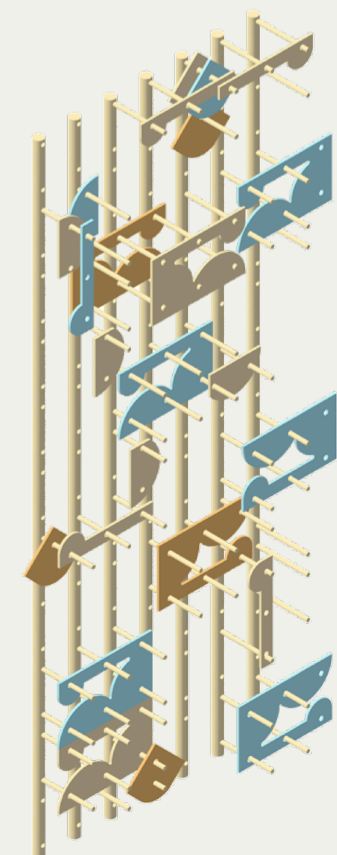

how do you make eggshell waste to insect space?

- ingredients**
 - 225g powdered eggshells
 - 225ml water
 - 9g sodium alginate
- equipment**
 - bowl
 - spoon/ tool to mix
 - plastic mould
 - dowel
- optional**
 - paintbrush
 - red cabbage/ turmeric/ beetroot dye/ dried powdered orange peels/ wood shavings

1 mix the powdered eggshells, water and sodium alginate into a bowl

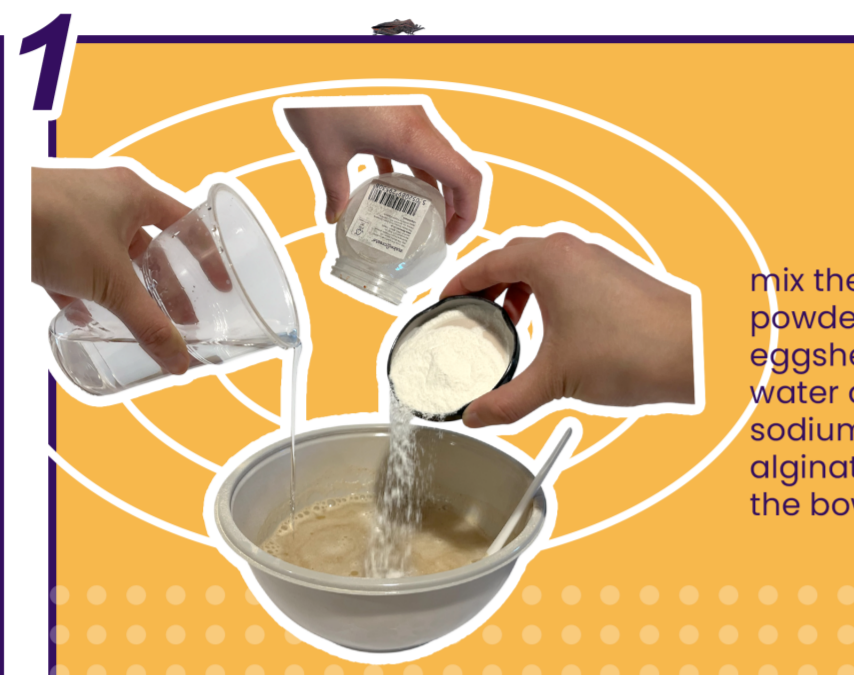

2 (optional) add in orange peels or wood shaving or the tumeric, red cabbage or beetroot dye

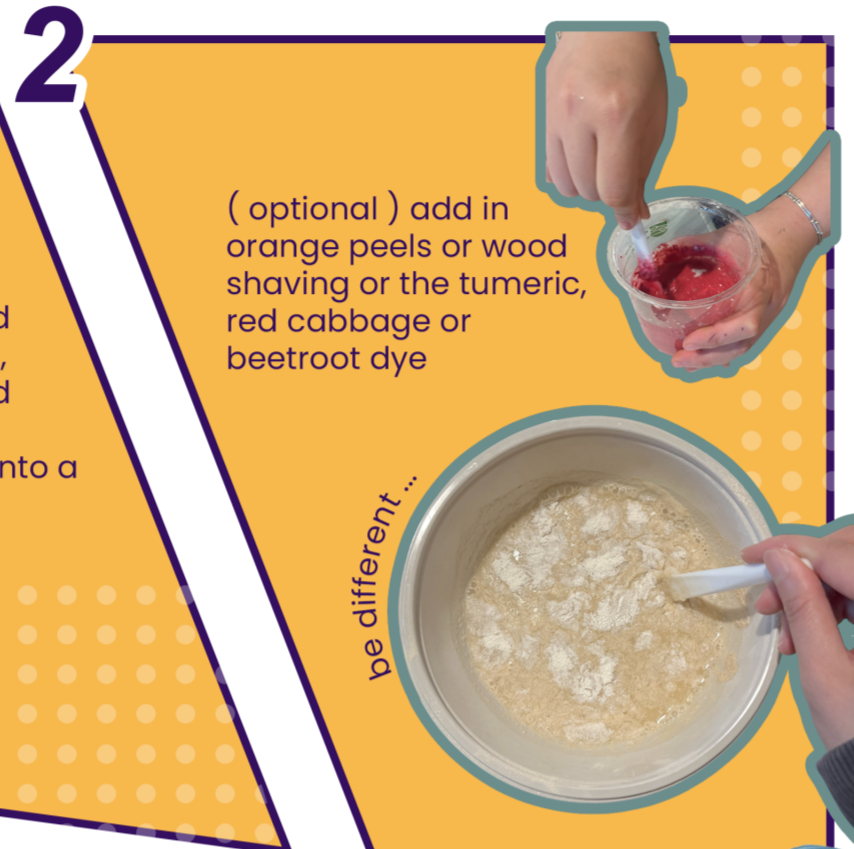

be different ...

3 put the mixture into the plastic mould



use the spoon/ tool to spread it out evenly and squish it down



4 let it air dry for 24 hours ...



5 go crazy!

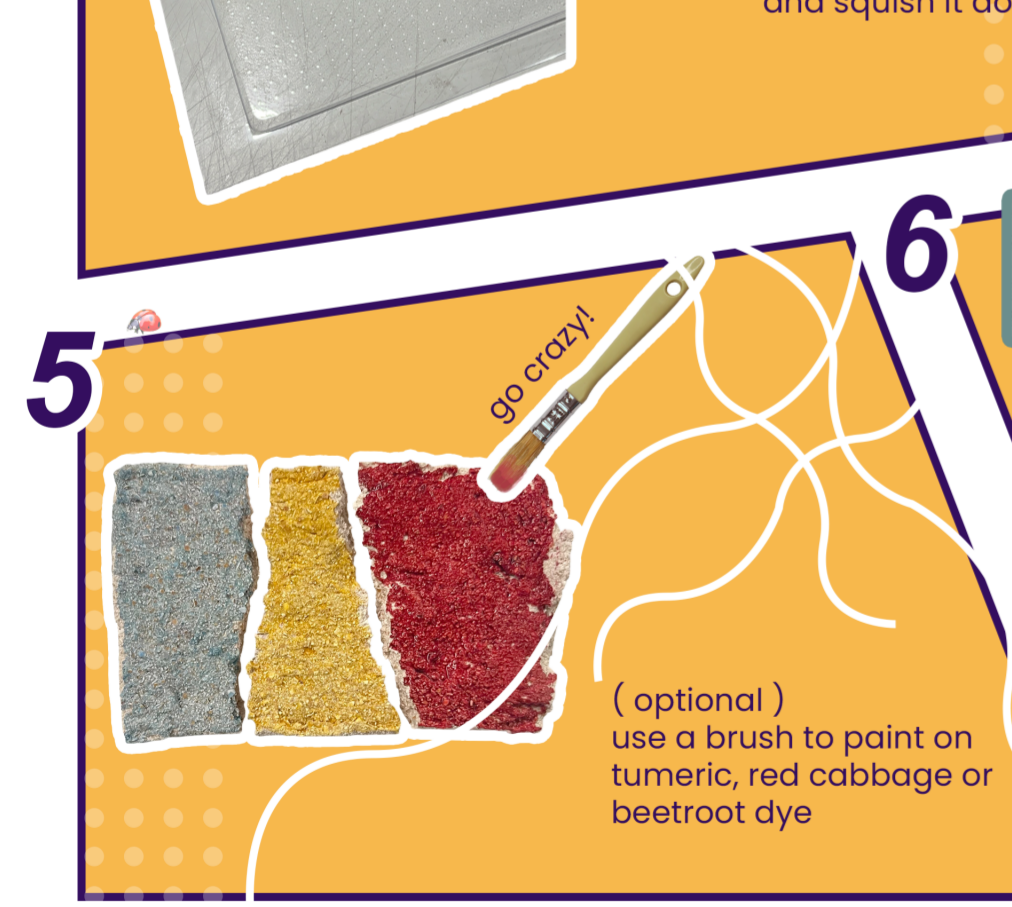

(optional) use a brush to paint on tumeric, red cabbage or beetroot dye

6 next to the barn, push the the dowels into place and put your finished eggshell tile through

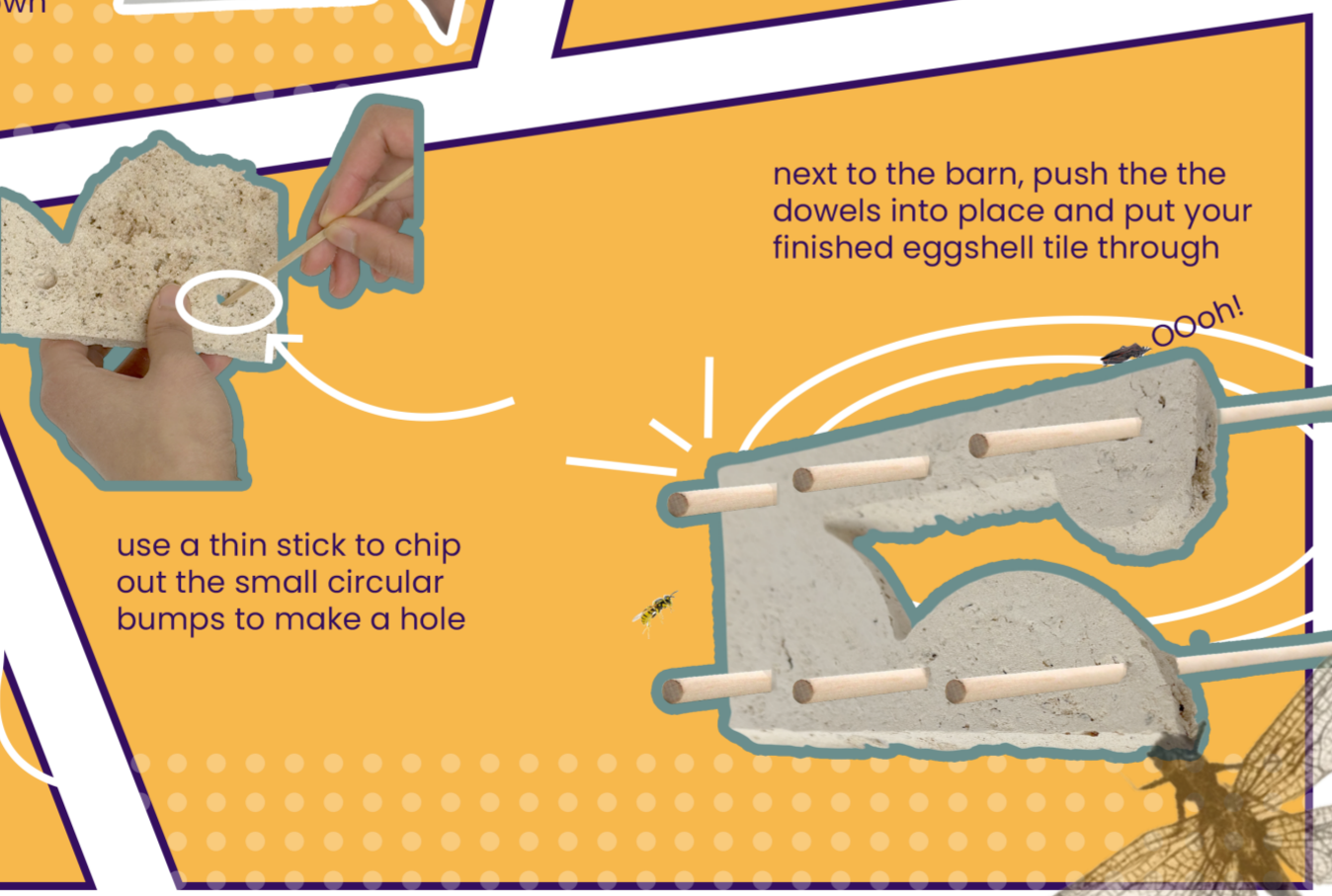

use a thin stick to chip out the small circular bumps to make a hole

oooh!

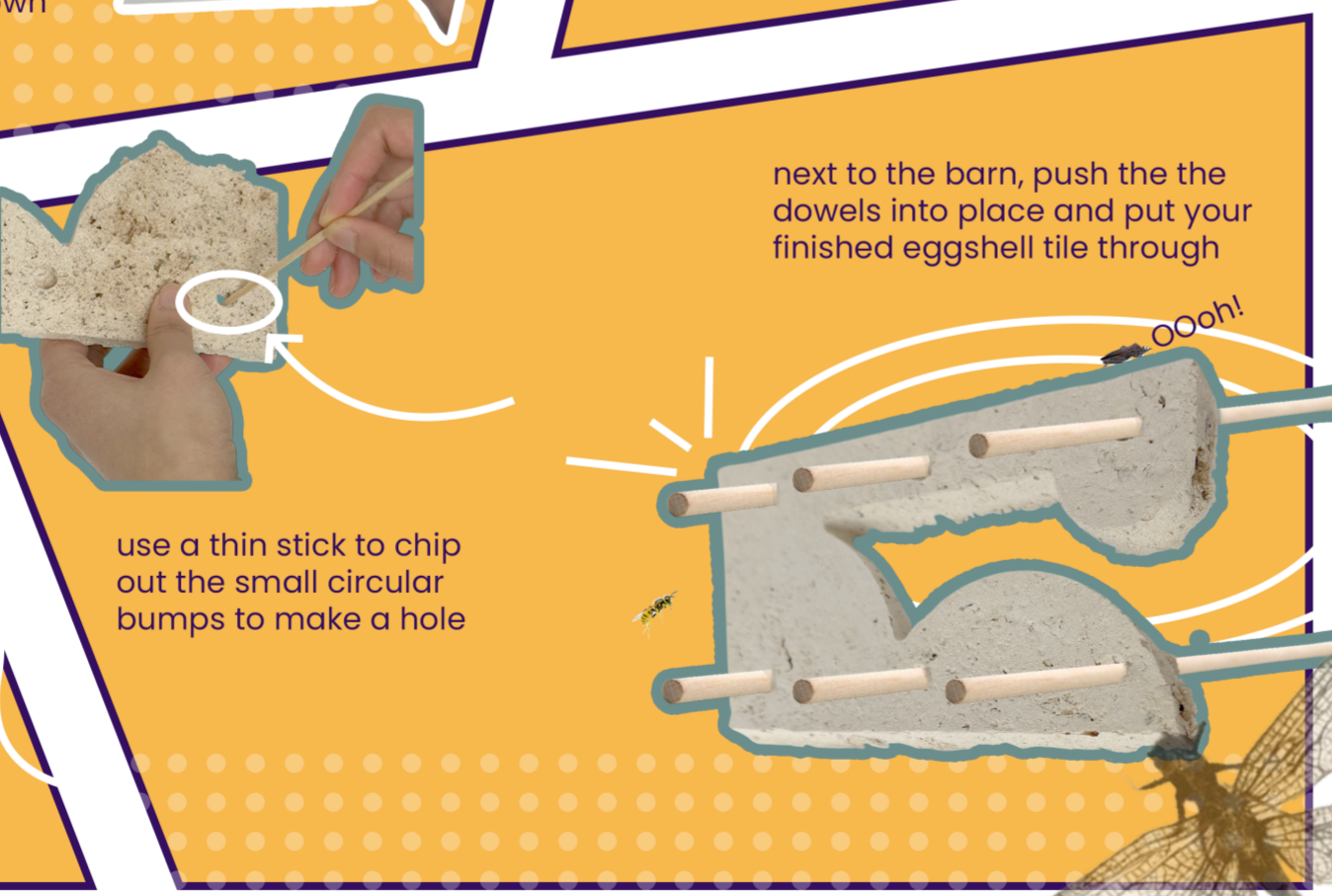

By simplifying the process through our own experimentation, we created a more accessible and enjoyable making experience for children.



A small act within a massive system

An eco-friendly workshop designed for children in Tolworth. We will be collecting food waste such as eggshells and this will be the first step in providing the main ingredients for children to create safe, sustainable, and non-toxic tiles that also serve as insect habitats. This project embeds the message that "even small human actions can contribute to animals, plants, and insects within a much larger ecological system."

